

NEGATIVE VOLTAGE REGULATORS

- OUTPUT CURRENT UP TO 1.5A
- OUTPUT VOLTAGES OF -5; -6; -8; -12; -15; -18; -20; -24V
- THERMAL OVERLOAD PROTECTION
- SHORT CIRCUIT PROTECTION
- OUTPUT TRANSITION SOA PROTECTION

DESCRIPTION

The L7900 series of three-terminal negative regulators is available in TO-220, TO-220FP, TO-3 and D²PAK packages and several fixed output voltages, making it useful in a wide range of applications. These regulators can provide local on-card regulation, eliminating the distribution problems associated with single point regulation; furthermore, having the same voltage option as the L7800 positive standard series, they are particularly suited for split power supplies. If adequate heat sinking is provided, they can deliver over 1.5A output current.

Although designed primarily as fixed voltage regulators, these devices can be used with external components to obtain adjustable voltages and currents.

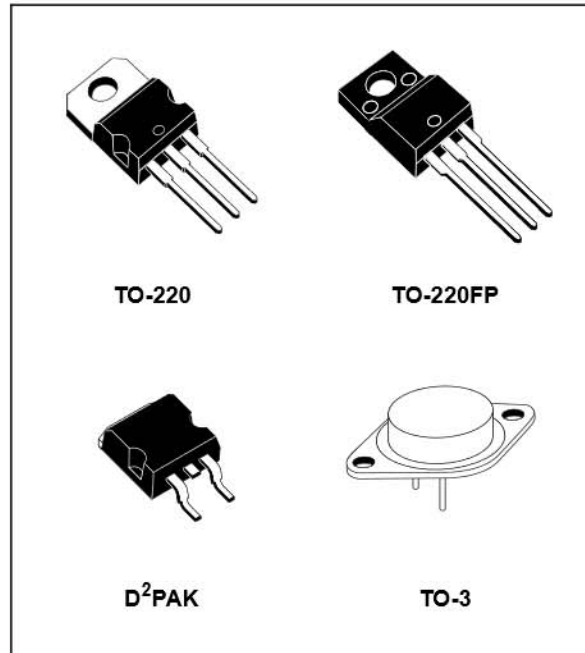

SCHEMATIC DIAGRAM

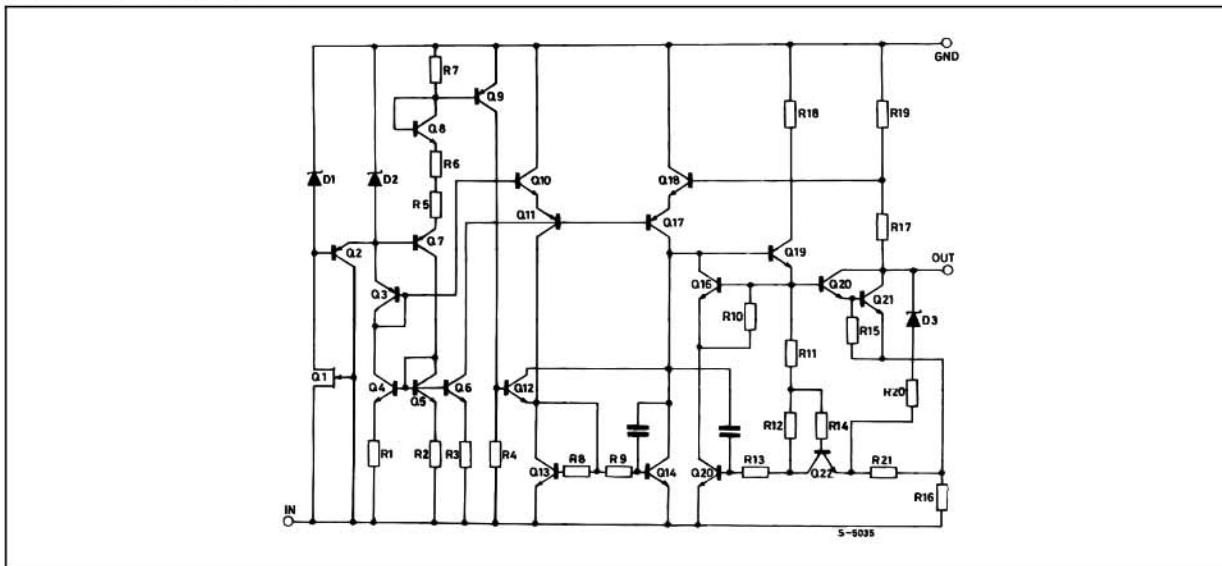

Table 1: Absolute Maximum Ratings

Symbol	Parameter		Value	Unit
V_I	DC Input Voltage	for $V_O = 5$ to $18V$	-35	V
		for $V_O = 20, 24V$	-40	
I_O	Output Current		Internally Limited	
P_{tot}	Power Dissipation		Internally Limited	
T_{stg}	Storage Temperature Range		-65 to 150	°C
T_{op}	Operating Junction Temperature Range		0 to 150	°C

Absolute Maximum Ratings are those values beyond which damage to the device may occur. Functional operation under these condition is not implied.

Table 2: Thermal Data

Symbol	Parameter		D ² PAK	TO-220	TO-220FP	TO-3	Unit
$R_{thj-case}$	Thermal Resistance Junction-case	Max	3	3	5	4	°C/W
$R_{thj-amb}$	Thermal Resistance Junction-ambient	Max	62.5	50	60	35	°C/W

Figure 1: Connection Diagram (top view)

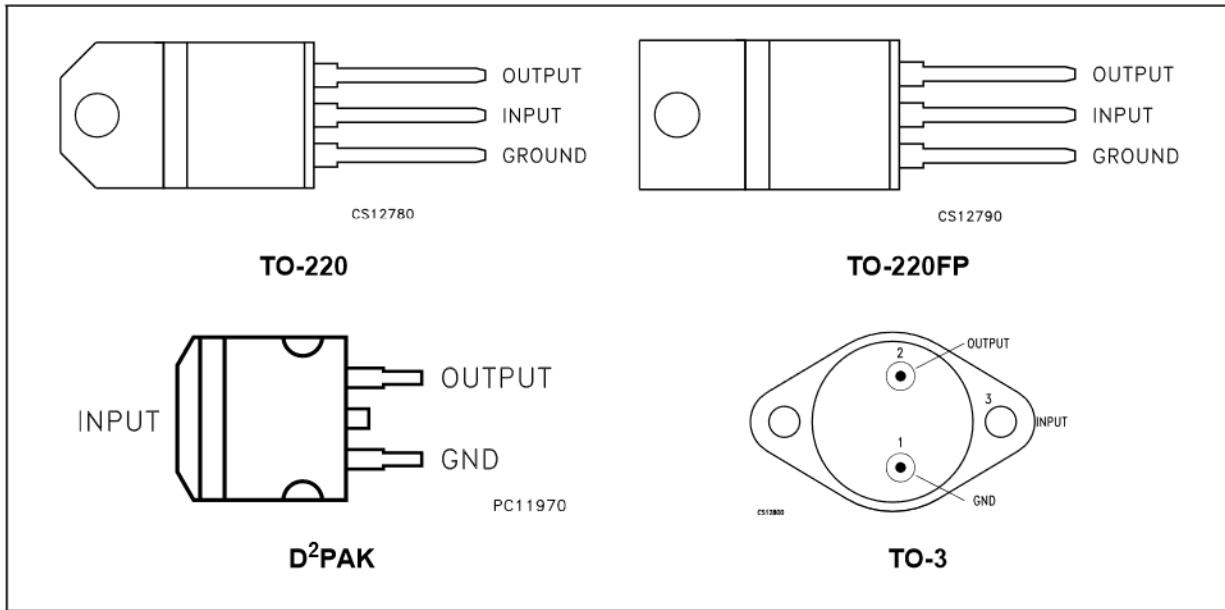

Table 3: Ordering Codes

TYPE	TO-220 (A Type)	TO-220 (C Type)	D ² PAK (A Type) (#)	D ² PAK (C Type) (T & R)	TO-220FP	TO-3	OUTPUT VOLTAGE
L7905C	L7905CV	L7905C-V	L7905CD2T	L7905C-D2TR	L7905CP	L7905CT (*)	-5 V
L7906C	L7906CV		L7906CD2T		L7906CP (*)	L7906CT (*)	-6 V
L7908C	L7908CV		L7908CD2T		L7908CP (*)	L7908CT (*)	-8 V
L7912C	L7912CV	L7912C-V	L7912CD2T		L7912CP	L7912CT (*)	-12 V
L7915C	L7915CV		L7915CD2T		L7915CP	L7915CT	-15 V
L7918C	L7918CV		L7918CD2T(*)		L7918CP (*)	L7918CT (*)	-18 V
L7920C	L7920CV		L7920CD2T(*)		L7920CP (*)	L7920CT (*)	-20 V
L7924C	L7924CV		L7924CD2T(*)		L7924CP (*)	L7924CT	-24 V

(#) Available in Tape & Reel with the suffix "-TR".

(*) Available on Request.

Figure 2: Test Circuit

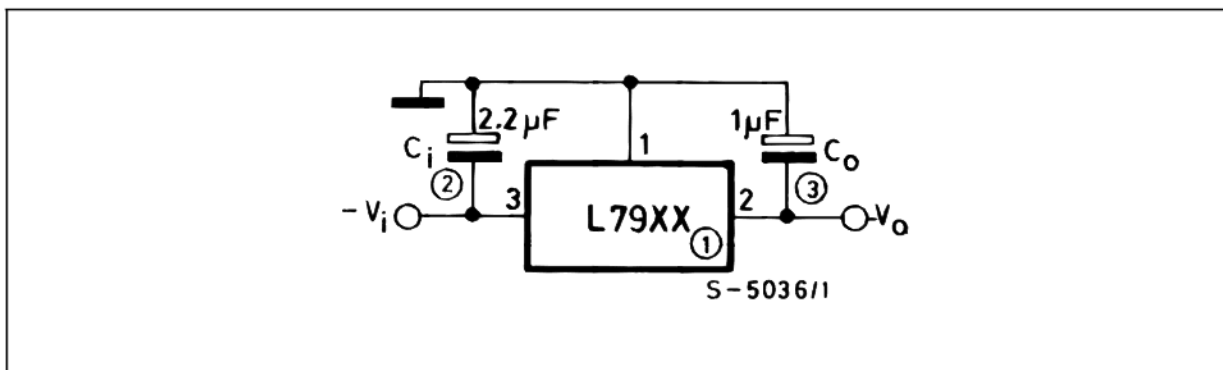

Table 4: Electrical Characteristics Of L7905C (refer to the test circuits, $T_J = 0$ to 125°C , $V_I = -10\text{V}$, $I_O = 500\text{ mA}$, $C_I = 2.2\ \mu\text{F}$, $C_O = 1\ \mu\text{F}$ unless otherwise specified).

Symbol	Parameter	Test Conditions	Min.	Typ.	Max.	Unit
V_O	Output Voltage	$T_J = 25^\circ\text{C}$	-4.8	-5	-5.2	V
V_O	Output Voltage	$I_O = -5\text{ mA to } -1\text{ A}$ $P_O \leq 15\text{ W}$ $V_I = 8\text{ to } 20\text{ V}$	-4.75	-5	-5.25	V
ΔV_O (*)	Line Regulation	$V_I = -7\text{ to } -25\text{ V}$ $T_J = 25^\circ\text{C}$			100	mV
		$V_I = -8\text{ to } -12\text{ V}$ $T_J = 25^\circ\text{C}$			50	
ΔV_O (*)	Load Regulation	$I_O = 5\text{ mA to } 1.5\text{ A}$ $T_J = 25^\circ\text{C}$			100	mV
		$I_O = 250\text{ to } 750\text{ mA}$ $T_J = 25^\circ\text{C}$			50	
I_d	Quiescent Current	$T_J = 25^\circ\text{C}$			3	mA
ΔI_d	Quiescent Current Change	$I_O = 5\text{ mA to } 1\text{ A}$ $V_I = -8\text{ to } -25\text{ V}$			0.5 1.3	mA
$\Delta V_O/\Delta T$	Output Voltage Drift	$I_O = 5\text{ mA}$		-0.4		mV/ $^\circ\text{C}$
eN	Output Noise Voltage	$B = 10\text{Hz to } 100\text{KHz}$ $T_J = 25^\circ\text{C}$		100		μV
SVR	Supply Voltage Rejection	$\Delta V_I = 10\text{ V}$ $f = 120\text{Hz}$	54	60		dB
V_d	Dropout Voltage	$I_O = 1\text{ A}$ $T_J = 25^\circ\text{C}$ $\Delta V_O = 100\text{ mV}$		1.4		V
I_{sc}	Short Circuit Current			2.1		A

(*) Load and line regulation are specified at constant junction temperature. Changes in V_O due to heating effects must be taken into account separately. Pulse testing with low duty cycle is used.

Table 5: Electrical Characteristics Of L7906C (refer to the test circuits, $T_J = 0$ to 125°C , $V_I = -11\text{V}$, $I_O = 500$ mA, $C_I = 2.2$ μF , $C_O = 1$ μF unless otherwise specified).

Symbol	Parameter	Test Conditions	Min.	Typ.	Max.	Unit
V_O	Output Voltage	$T_J = 25^\circ\text{C}$	-5.75	-6	-6.25	V
V_O	Output Voltage	$I_O = -5$ mA to -1 A $P_O \leq 15$ W $V_I = -9.5$ to -21.5 V	-5.7	-6	-6.3	V
$\Delta V_{O(*)}$	Line Regulation	$V_I = -8.5$ to -25 V $T_J = 25^\circ\text{C}$			120	mV
		$V_I = -9$ to -15 V $T_J = 25^\circ\text{C}$			60	
$\Delta V_{O(*)}$	Load Regulation	$I_O = 5$ mA to 1.5 A $T_J = 25^\circ\text{C}$			120	mV
		$I_O = 250$ to 750 mA $T_J = 25^\circ\text{C}$			60	
I_d	Quiescent Current	$T_J = 25^\circ\text{C}$			3	mA
ΔI_d	Quiescent Current Change	$I_O = 5$ mA to 1 A			0.5	mA
		$V_I = -9.5$ to -25 V			1.3	
$\Delta V_O/\Delta T$	Output Voltage Drift	$I_O = 5$ mA		-0.6		mV/ $^\circ\text{C}$
eN	Output Noise Voltage	$B = 10\text{Hz}$ to 100KHz $T_J = 25^\circ\text{C}$		144		μV
SVR	Supply Voltage Rejection	$\Delta V_I = 10$ V $f = 120\text{Hz}$	54	60		dB
V_d	Dropout Voltage	$I_O = 1$ A $T_J = 25^\circ\text{C}$ $\Delta V_O = 100$ mV		1.4		V
I_{sc}	Short Circuit Current			2		A

(*) Load and line regulation are specified at constant junction temperature. Changes in V_O due to heating effects must be taken into account separately. Pulse testing with low duty cycle is used.

Table 6: Electrical Characteristics Of L7908C (refer to the test circuits, $T_J = 0$ to 125°C , $V_I = -14\text{V}$, $I_O = 500$ mA, $C_I = 2.2$ μF , $C_O = 1$ μF unless otherwise specified).

Symbol	Parameter	Test Conditions	Min.	Typ.	Max.	Unit
V_O	Output Voltage	$T_J = 25^\circ\text{C}$	-7.7	-8	-8.3	V
V_O	Output Voltage	$I_O = -5$ mA to -1 A $P_O \leq 15$ W $V_I = -11.5$ to -23 V	-7.6	-8	-8.4	V
$\Delta V_{O(*)}$	Line Regulation	$V_I = -10.5$ to -25 V $T_J = 25^\circ\text{C}$			160	mV
		$V_I = -11$ to -17 V $T_J = 25^\circ\text{C}$			80	
$\Delta V_{O(*)}$	Load Regulation	$I_O = 5$ mA to 1.5 A $T_J = 25^\circ\text{C}$			160	mV
		$I_O = 250$ to 750 mA $T_J = 25^\circ\text{C}$			80	
I_d	Quiescent Current	$T_J = 25^\circ\text{C}$			3	mA
ΔI_d	Quiescent Current Change	$I_O = 5$ mA to 1 A			0.5	mA
		$V_I = -11.5$ to -25 V			1	
$\Delta V_O/\Delta T$	Output Voltage Drift	$I_O = 5$ mA		-0.6		mV/ $^\circ\text{C}$
eN	Output Noise Voltage	$B = 10\text{Hz}$ to 100KHz $T_J = 25^\circ\text{C}$		175		μV
SVR	Supply Voltage Rejection	$\Delta V_I = 10$ V $f = 120\text{Hz}$	54	60		dB
V_d	Dropout Voltage	$I_O = 1$ A $T_J = 25^\circ\text{C}$ $\Delta V_O = 100$ mV		1.1		V
I_{sc}	Short Circuit Current			1.5		A

(*) Load and line regulation are specified at constant junction temperature. Changes in V_O due to heating effects must be taken into account separately. Pulse testing with low duty cycle is used.

Table 7: Electrical Characteristics Of L7912C (refer to the test circuits, $T_J = 0$ to 125°C , $V_I = -19\text{V}$, $I_O = 500$ mA, $C_I = 2.2$ μF , $C_O = 1$ μF unless otherwise specified).

Symbol	Parameter	Test Conditions	Min.	Typ.	Max.	Unit
V_O	Output Voltage	$T_J = 25^\circ\text{C}$	-11.5	-12	-12.5	V
V_O	Output Voltage	$I_O = -5$ mA to -1 A $P_O \leq 15$ W $V_I = -15.5$ to -27 V	-11.4	-12	-12.6	V
$\Delta V_{O(*)}$	Line Regulation	$V_I = -14.5$ to -30 V $T_J = 25^\circ\text{C}$			240	mV
		$V_I = -16$ to -22 V $T_J = 25^\circ\text{C}$			120	
$\Delta V_{O(*)}$	Load Regulation	$I_O = 5$ mA to 1.5 A $T_J = 25^\circ\text{C}$			240	mV
		$I_O = 250$ to 750 mA $T_J = 25^\circ\text{C}$			120	
I_d	Quiescent Current	$T_J = 25^\circ\text{C}$			3	mA
ΔI_d	Quiescent Current Change	$I_O = 5$ mA to 1 A			0.5	mA
		$V_I = -15$ to -30 V			1	
$\Delta V_O/\Delta T$	Output Voltage Drift	$I_O = 5$ mA		-0.8		mV/ $^\circ\text{C}$
eN	Output Noise Voltage	$B = 10\text{Hz}$ to 100KHz $T_J = 25^\circ\text{C}$		200		μV
SVR	Supply Voltage Rejection	$\Delta V_I = 10$ V $f = 120\text{Hz}$	54	60		dB
V_d	Dropout Voltage	$I_O = 1$ A $T_J = 25^\circ\text{C}$ $\Delta V_O = 100$ mV		1.1		V
I_{sc}	Short Circuit Current			1.5		A

(*) Load and line regulation are specified at constant junction temperature. Changes in V_O due to heating effects must be taken into account separately. Pulse testing with low duty cycle is used.

Table 8: Electrical Characteristics Of L7915C (refer to the test circuits, $T_J = 0$ to 125°C , $V_I = -23\text{V}$, $I_O = 500$ mA, $C_I = 2.2$ μF , $C_O = 1$ μF unless otherwise specified).

Symbol	Parameter	Test Conditions	Min.	Typ.	Max.	Unit
V_O	Output Voltage	$T_J = 25^\circ\text{C}$	-14.4	-15	-15.6	V
V_O	Output Voltage	$I_O = -5$ mA to -1 A $P_O \leq 15$ W $V_I = -18.5$ to -30 V	-14.3	-15	-15.7	V
$\Delta V_{O(*)}$	Line Regulation	$V_I = -17.5$ to -30 V $T_J = 25^\circ\text{C}$			300	mV
		$V_I = -20$ to -26 V $T_J = 25^\circ\text{C}$			150	
$\Delta V_{O(*)}$	Load Regulation	$I_O = 5$ mA to 1.5 A $T_J = 25^\circ\text{C}$			300	mV
		$I_O = 250$ to 750 mA $T_J = 25^\circ\text{C}$			150	
I_d	Quiescent Current	$T_J = 25^\circ\text{C}$			3	mA
ΔI_d	Quiescent Current Change	$I_O = 5$ mA to 1 A			0.5	mA
		$V_I = -18.5$ to -30 V			1	
$\Delta V_O/\Delta T$	Output Voltage Drift	$I_O = 5$ mA		-0.9		mV/ $^\circ\text{C}$
eN	Output Noise Voltage	$B = 10\text{Hz}$ to 100KHz $T_J = 25^\circ\text{C}$		250		μV
SVR	Supply Voltage Rejection	$\Delta V_I = 10$ V $f = 120\text{Hz}$	54	60		dB
V_d	Dropout Voltage	$I_O = 1$ A $T_J = 25^\circ\text{C}$ $\Delta V_O = 100$ mV		1.1		V
I_{sc}	Short Circuit Current			1.3		A

(*) Load and line regulation are specified at constant junction temperature. Changes in V_O due to heating effects must be taken into account separately. Pulse testing with low duty cycle is used.

Table 9: Electrical Characteristics Of L7918C (refer to the test circuits, $T_J = 0$ to 125°C , $V_I = -27\text{V}$, $I_O = 500$ mA, $C_I = 2.2$ μF , $C_O = 1$ μF unless otherwise specified).

Symbol	Parameter	Test Conditions	Min.	Typ.	Max.	Unit
V_O	Output Voltage	$T_J = 25^\circ\text{C}$	-17.3	-18	-18.7	V
V_O	Output Voltage	$I_O = -5$ mA to -1 A $P_O \leq 15$ W $V_I = -22$ to -33 V	-17.1	-18	-18.9	V
$\Delta V_{O(*)}$	Line Regulation	$V_I = -21$ to -33 V $T_J = 25^\circ\text{C}$			360	mV
		$V_I = -24$ to -30 V $T_J = 25^\circ\text{C}$			180	
$\Delta V_{O(*)}$	Load Regulation	$I_O = 5$ mA to 1.5 A $T_J = 25^\circ\text{C}$			360	mV
		$I_O = 250$ to 750 mA $T_J = 25^\circ\text{C}$			180	
I_d	Quiescent Current	$T_J = 25^\circ\text{C}$			3	mA
ΔI_d	Quiescent Current Change	$I_O = 5$ mA to 1 A			0.5	mA
		$V_I = -22$ to -33 V			1	
$\Delta V_O/\Delta T$	Output Voltage Drift	$I_O = 5$ mA		-1		mV/ $^\circ\text{C}$
eN	Output Noise Voltage	$B = 10\text{Hz}$ to 100KHz $T_J = 25^\circ\text{C}$		300		μV
SVR	Supply Voltage Rejection	$\Delta V_I = 10$ V $f = 120\text{Hz}$	54	60		dB
V_d	Dropout Voltage	$I_O = 1$ A $T_J = 25^\circ\text{C}$ $\Delta V_O = 100$ mV		1.1		V
I_{sc}	Short Circuit Current			1.1		A

(*) Load and line regulation are specified at constant junction temperature. Changes in V_O due to heating effects must be taken into account separately. Pulse testing with low duty cycle is used.

Table 10: Electrical Characteristics Of L7920C (refer to the test circuits, $T_J = 0$ to 125°C , $V_I = -29\text{V}$, $I_O = 500$ mA, $C_I = 2.2$ μF , $C_O = 1$ μF unless otherwise specified).

Symbol	Parameter	Test Conditions	Min.	Typ.	Max.	Unit
V_O	Output Voltage	$T_J = 25^\circ\text{C}$	-19.2	-20	-20.8	V
V_O	Output Voltage	$I_O = -5$ mA to -1 A $P_O \leq 15$ W $V_I = -24$ to -35 V	-19	-20	-21	V
$\Delta V_{O(*)}$	Line Regulation	$V_I = -23$ to -35 V $T_J = 25^\circ\text{C}$			400	mV
		$V_I = -26$ to -32 V $T_J = 25^\circ\text{C}$			200	
$\Delta V_{O(*)}$	Load Regulation	$I_O = 5$ mA to 1.5 A $T_J = 25^\circ\text{C}$			400	mV
		$I_O = 250$ to 750 mA $T_J = 25^\circ\text{C}$			200	
I_d	Quiescent Current	$T_J = 25^\circ\text{C}$			3	mA
ΔI_d	Quiescent Current Change	$I_O = 5$ mA to 1 A			0.5	mA
		$V_I = -24$ to -35 V			1	
$\Delta V_O/\Delta T$	Output Voltage Drift	$I_O = 5$ mA		-1.1		mV/ $^\circ\text{C}$
eN	Output Noise Voltage	$B = 10\text{Hz}$ to 100KHz $T_J = 25^\circ\text{C}$		350		μV
SVR	Supply Voltage Rejection	$\Delta V_I = 10$ V $f = 120\text{Hz}$	54	60		dB
V_d	Dropout Voltage	$I_O = 1$ A $T_J = 25^\circ\text{C}$ $\Delta V_O = 100$ mV		1.1		V
I_{sc}	Short Circuit Current			0.9		A

(*) Load and line regulation are specified at constant junction temperature. Changes in V_O due to heating effects must be taken into account separately. Pulse testing with low duty cycle is used.

Table 11: Electrical Characteristics Of L7924C (refer to the test circuits, $T_J = 0$ to 125°C , $V_I = -33\text{V}$, $I_O = 500$ mA, $C_I = 2.2$ μF , $C_O = 1$ μF unless otherwise specified).

Symbol	Parameter	Test Conditions	Min.	Typ.	Max.	Unit
V_O	Output Voltage	$T_J = 25^\circ\text{C}$	-23	-24	-24.5	V
V_O	Output Voltage	$I_O = -5$ mA to -1 A $P_O \leq 15$ W $V_I = -27$ to -38 V	-22.8	-24	-25.2	V
$\Delta V_{O(*)}$	Line Regulation	$V_I = -27$ to -38 V $T_J = 25^\circ\text{C}$			480	mV
		$V_I = -30$ to -36 V $T_J = 25^\circ\text{C}$			240	
$\Delta V_{O(*)}$	Load Regulation	$I_O = 5$ mA to 1.5 A $T_J = 25^\circ\text{C}$			480	mV
		$I_O = 250$ to 750 mA $T_J = 25^\circ\text{C}$			240	
I_d	Quiescent Current	$T_J = 25^\circ\text{C}$			3	mA
ΔI_d	Quiescent Current Change	$I_O = 5$ mA to 1 A			0.5	mA
		$V_I = -27$ to -38 V			1	
$\Delta V_O/\Delta T$	Output Voltage Drift	$I_O = 5$ mA		-1		mV/ $^\circ\text{C}$
eN	Output Noise Voltage	$B = 10\text{Hz}$ to 100KHz $T_J = 25^\circ\text{C}$		400		μV
SVR	Supply Voltage Rejection	$\Delta V_I = 10$ V $f = 120\text{Hz}$	54	60		dB
V_d	Dropout Voltage	$I_O = 1$ A $T_J = 25^\circ\text{C}$ $\Delta V_O = 100$ mV		1.1		V
I_{sc}	Short Circuit Current			1.1		A

(*) Load and line regulation are specified at constant junction temperature. Changes in V_O due to heating effects must be taken into account separately. Pulse testing with low duty cycle is used.

APPLICATIONS INFORMATION

Figure 3: Fixed Output Regulator

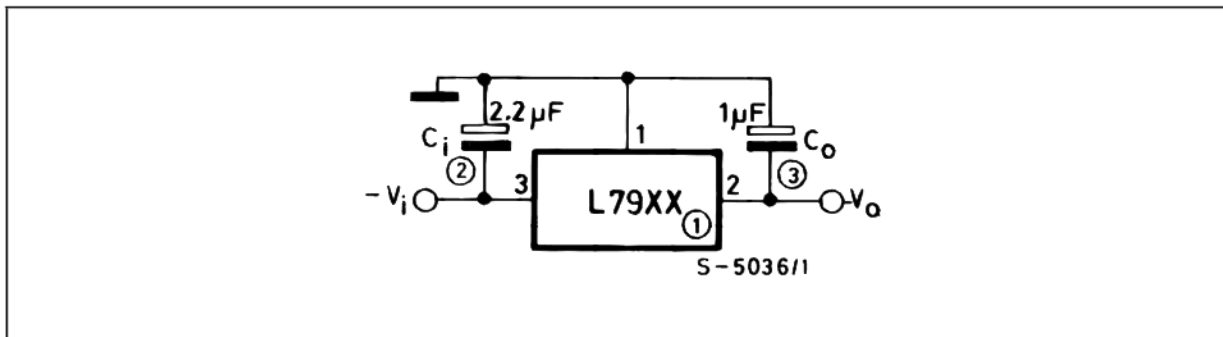

NOTE:

1. To specify an output voltage, substitute voltage value for "XX".
2. Required for stability. For value given, capacitor must be solid tantalum. If aluminium electrolytics are used, at least ten times value should be selected. C1 is required if regulator is located an appreciable distance from power supply filter.
3. To improve transient response. If large capacitors are used, a high current diode from input to output (1N4001 or similar) should be introduced to protect the device from momentary input short circuit.

Figure 4: Split Power Supply ($\pm 15V/1A$)

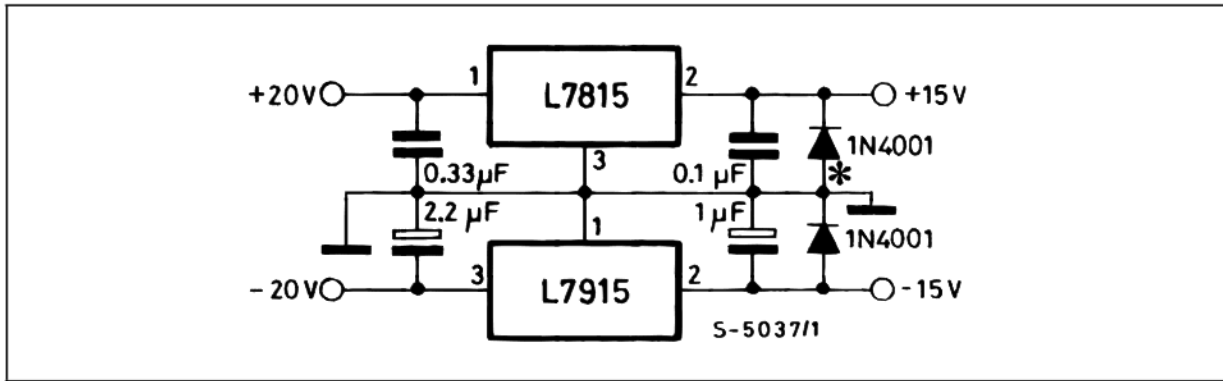

Against potential latch-up problems.

Figure 5: Circuit for Increasing Output Voltage

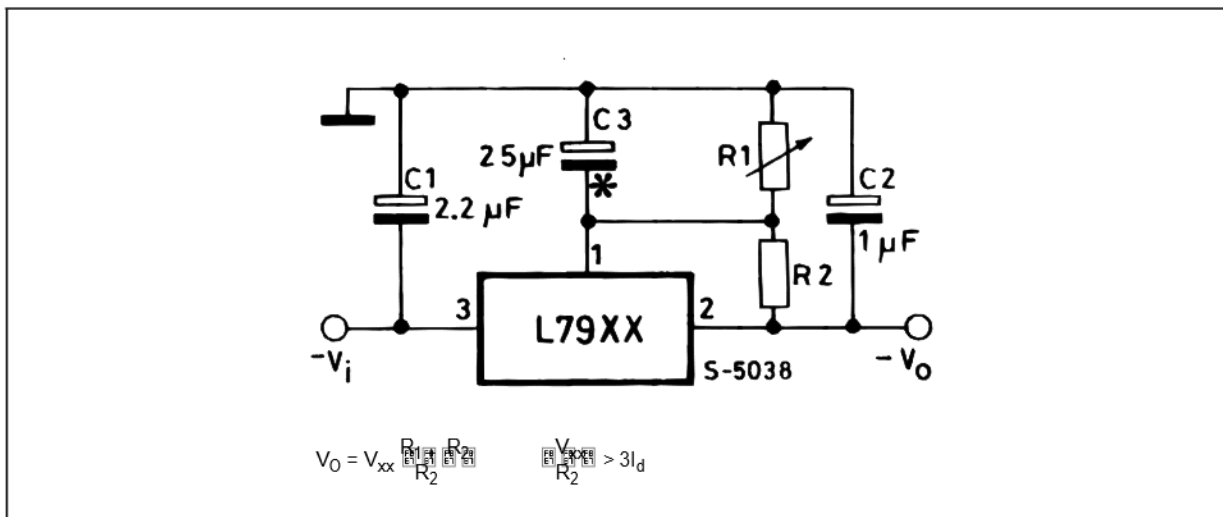

C3 Optional for improved transient response and ripple rejection.

Figure 6: High Current Negative Regulator ($-5V/4A$ with 5A current limiting)

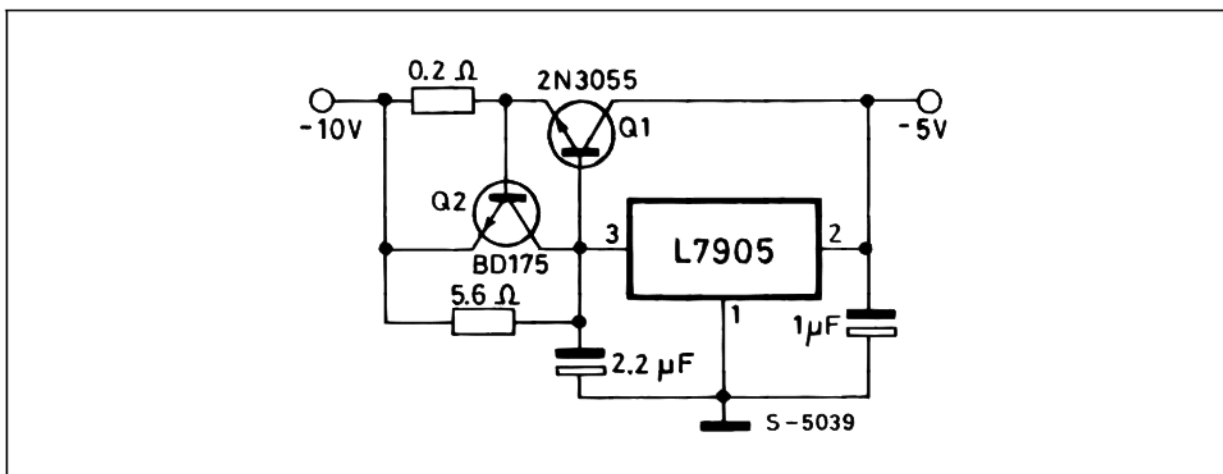

TO-3 MECHANICAL DATA

DIM.	mm.			inch		
	MIN.	TYP.	MAX.	MIN.	TYP.	MAX.
A		11.85			0.466	
B	0.96	1.05	1.10	0.037	0.041	0.043
C			1.70			0.066
D			8.7			0.342
E			20.0			0.787
G		10.9			0.429	
N		16.9			0.665	
P			26.2			1.031
R	3.88		4.09	0.152		0.161
U			39.5			1.555
V		30.10			1.185	

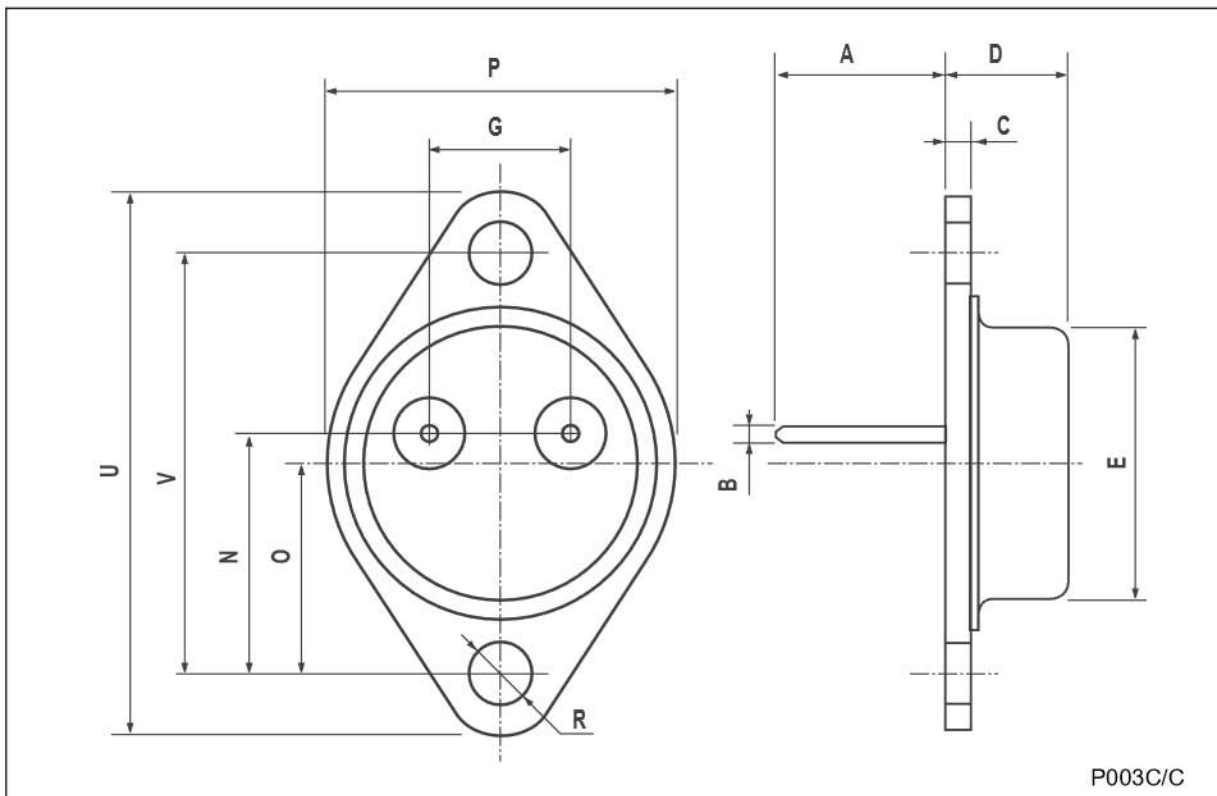

P003C/C

TO-220 (A TYPE) MECHANICAL DATA

DIM.	mm.			inch		
	MIN.	TYP.	MAX.	MIN.	TYP.	MAX.
A	4.40		4.60	0.173		0.181
b	0.61		0.88	0.024		0.034
b1	1.15		1.70	0.045		0.067
c	0.49		0.70	0.019		0.027
D	15.25		15.75	0.600		0.620
E	10.0		10.40	0.393		0.409
e	2.4		2.7	0.094		0.106
e1	4.95		5.15	0.194		0.203
F	1.23		1.32	0.048		0.051
H1	6.2		6.6	0.244		0.260
J1	2.40		2.72	0.094		0.107
L	13.0		14.0	0.511		0.551
L1	3.5		3.93	0.137		0.154
L20		16.4			0.645	
L30		28.9			1.138	
φP	3.75		3.85	0.147		0.151
Q	2.65		2.95	0.104		0.116

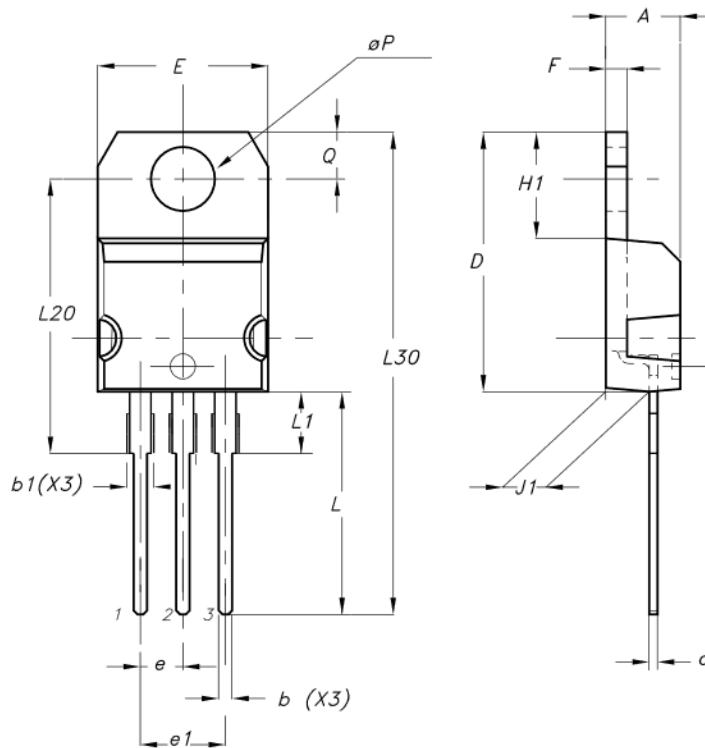

0015988/N

TO-220 (C TYPE) MECHANICAL DATA

DIM.	mm.			inch		
	MIN.	TYP.	MAX.	MIN.	TYP.	MAX.
A	4.30		4.70	0.169		0.185
b	0.70		0.90	0.028		0.035
b1	1.42		1.62	0.056		0.064
c	0.45		0.60	0.018		0.024
D		15.70			0.618	
E	9.80		10.20	0.386		0.402
e		2.54			0.100	
e1		5.08			0.200	
F	1.25		1.39	0.049		0.055
H1		6.5			0.256	
J1	2.20		2.60	0.087		0.202
L	12.88		13.28	0.507		0.523
L1		3			0.118	
L20	15.70		16.1	0.618		0.634
L30		28.9			1.138	
φP	3.50		3.70	0.138		0.146
Q	2.70		2.90	0.106		0.114

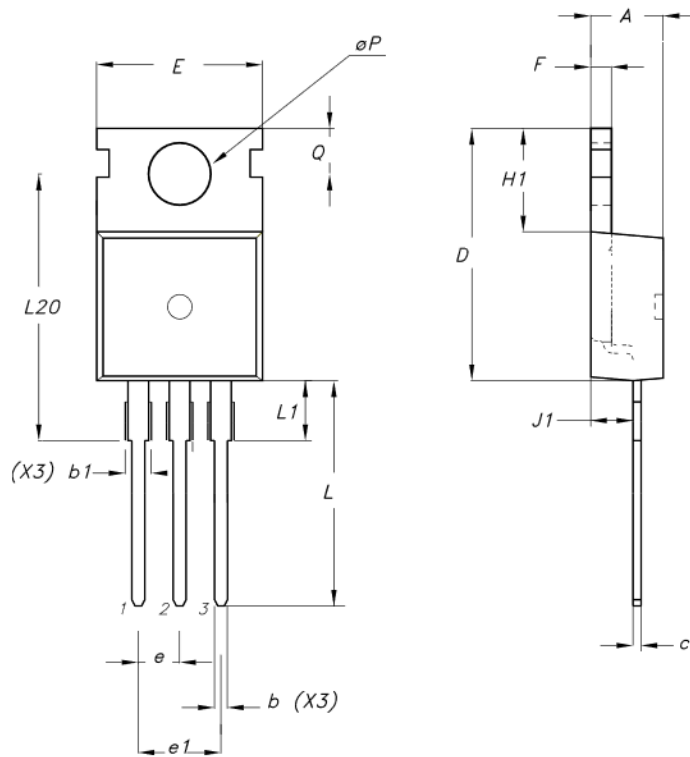

0015988/N

TO-220FP MECHANICAL DATA

DIM.	mm.			inch		
	MIN.	TYP	MAX.	MIN.	TYP.	MAX.
A	4.40		4.60	0.173		0.181
B	2.5		2.7	0.098		0.106
D	2.5		2.75	0.098		0.108
E	0.45		0.70	0.017		0.027
F	0.75		1	0.030		0.039
F1	1.15		1.50	0.045		0.059
F2	1.15		1.50	0.045		0.059
G	4.95		5.2	0.194		0.204
G1	2.4		2.7	0.094		0.106
H	10.0		10.40	0.393		0.409
L2		16			0.630	
L3	28.6		30.6	1.126		1.204
L4	9.8		10.6	0.385		0.417
L5	2.9		3.6	0.114		0.142
L6	15.9		16.4	0.626		0.645
L7	9		9.3	0.354		0.366
DIA.	3		3.2	0.118		0.126

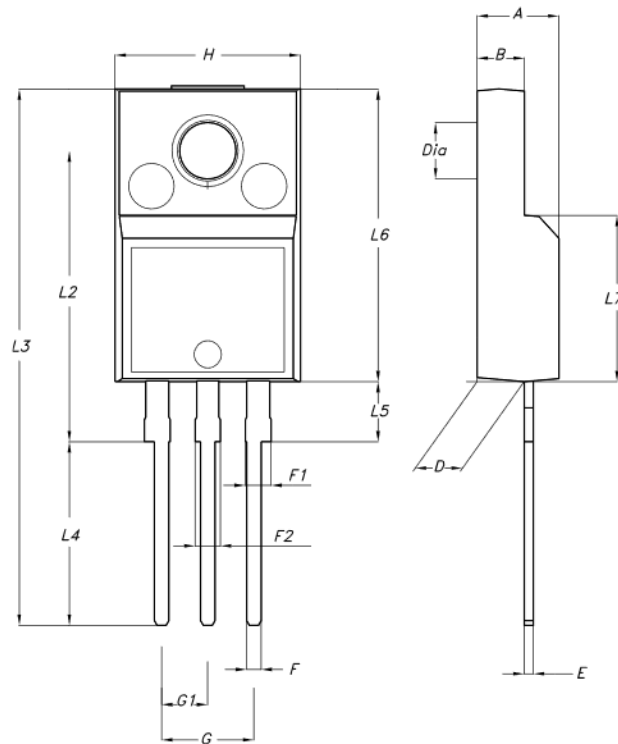

7012510A-H

D²PAK (A TYPE) MECHANICAL DATA

DIM.	mm.			inch		
	MIN.	TYP	MAX.	MIN.	TYP.	MAX.
A	4.4		4.6	0.173		0.181
A1	0.03		0.23	0.001		0.009
b	0.7		0.93	0.027		0.036
b2	1.14		1.7	0.044		0.067
c	0.45		0.6	0.017		0.023
c2	1.23		1.36	0.048		0.053
D	8.95		9.35	0.352		0.368
D1	8			0.315		
E	10		10.4	0.393		0.409
E1	8.5			0.335		
e		2.54			0.100	
e1	4.88		5.28	0.192		0.208
H	15		15.85	0.590		0.624
J1	2.49		2.69	0.098		0.106
L	2.29		2.79	0.090		0.110
L1	1.27		1.4	0.050		0.055
L2	1.3		1.75	0.051		0.069
R		0.4			0.016	
V2	0°		8°	0°		8°

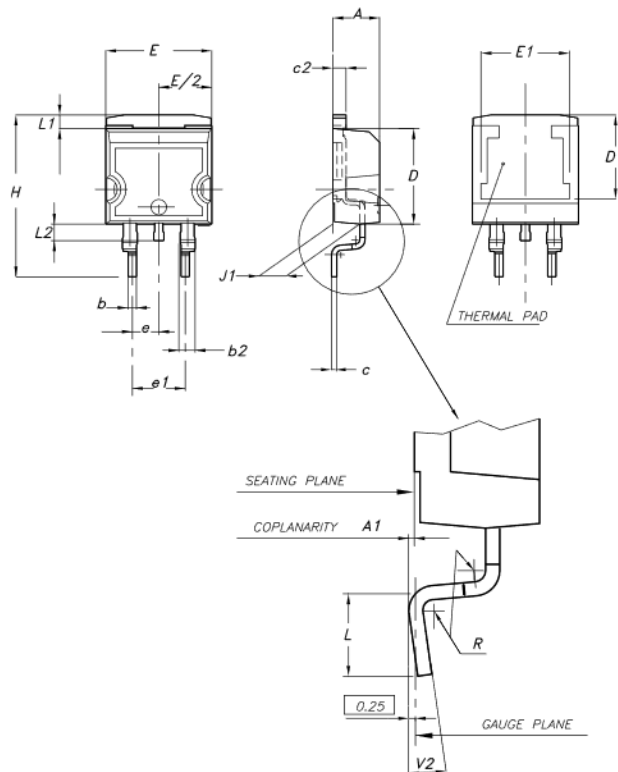

0079457/J

D²PAK (C TYPE) MECHANICAL DATA

DIM.	mm.			inch		
	MIN.	TYP	MAX.	MIN.	TYP.	MAX.
A	4.3		4.7	0.169		0.185
A1	0		0.20	0.000		0.008
b	0.70		0.90	0.028		0.035
b2	1.17		1.37	0.046		0.054
c	0.45	0.50	0.6	0.018	0.020	0.024
c2	1.25	1.30	1.40	0.049	0.051	0.055
D	9.0	9.2	9.4	0.354	0.362	0.370
D1	7.5			0.295		
E	9.8		10.2	0.386		0.402
E1	7.5			0.295		
e		2.54			0.100	
e1		5.08			0.200	
H	15	15.30	15.60	0.591	0.602	0.614
J1	2.20		2.60	0.087		0.102
L	1.79		2.79	0.070		0.110
L1	1.0		1.4	0.039		0.055
L2	1.2		1.6	0.047		0.063
R		0.3			0.012	
V2	0°		3°	0°		3°

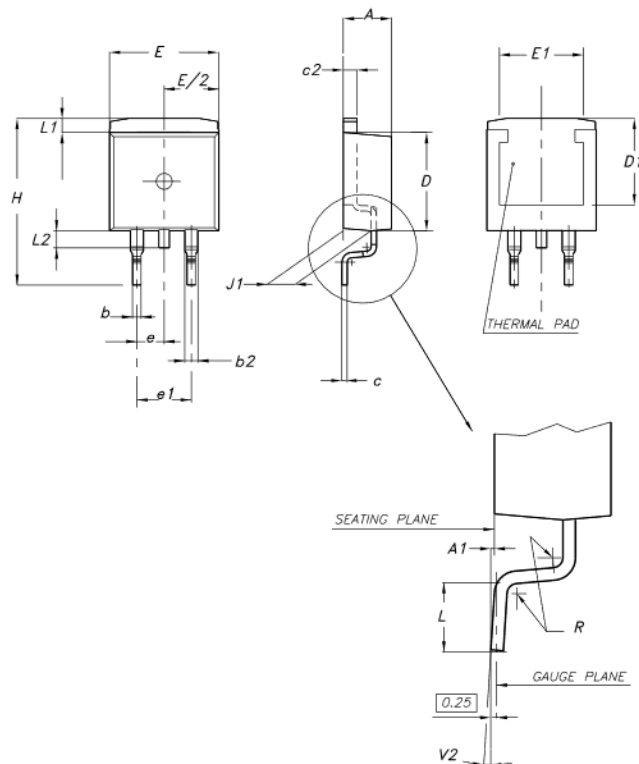

0079457/J

Tape & Reel D²PAK-P²PAK-D²PAK/A-P²PAK/A MECHANICAL DATA

DIM.	mm.			inch		
	MIN.	TYP	MAX.	MIN.	TYP.	MAX.
A			180			7.086
C	12.8	13.0	13.2	0.504	0.512	0.519
D	20.2			0.795		
N	60			2.362		
T			14.4			0.567
Ao	10.50	10.6	10.70	0.413	0.417	0.421
Bo	15.70	15.80	15.90	0.618	0.622	0.626
Ko	4.80	4.90	5.00	0.189	0.193	0.197
Po	3.9	4.0	4.1	0.153	0.157	0.161
P	11.9	12.0	12.1	0.468	0.472	0.476

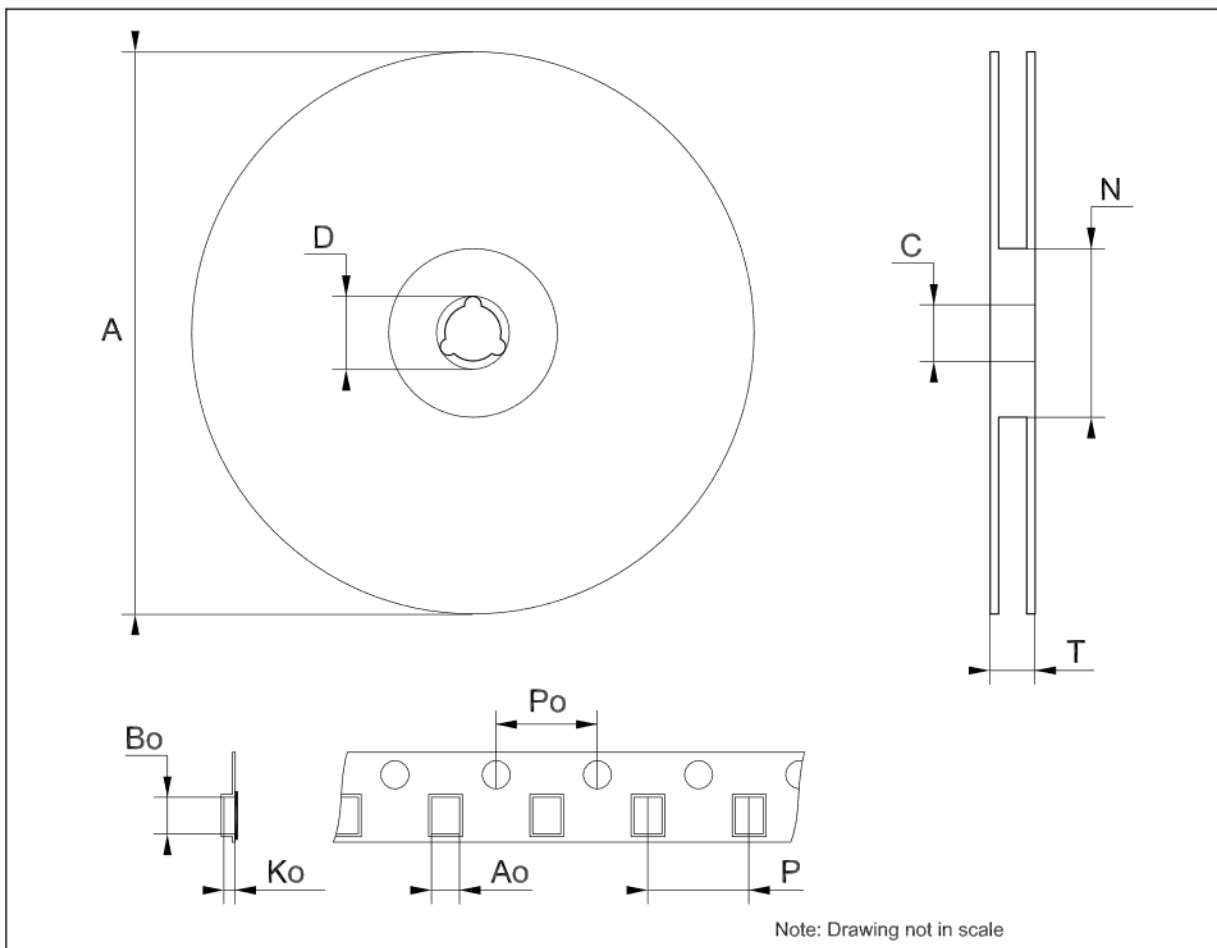

Table 12: Revision History

Date	Revision	Description of Changes
22-Jun-2004	9	Ordering Codes updated Table 3, pag. 3.

Information furnished is believed to be accurate and reliable. However, STMicroelectronics assumes no responsibility for the consequences of use of such information nor for any infringement of patents or other rights of third parties which may result from its use. No license is granted by implication or otherwise under any patent or patent rights of STMicroelectronics. Specifications mentioned in this publication are subject to change without notice. This publication supersedes and replaces all information previously supplied. STMicroelectronics products are not authorized for use as critical components in life support devices or systems without express written approval of STMicroelectronics.

The ST logo is a registered trademark of STMicroelectronics
All other names are the property of their respective owners

© 2004 STMicroelectronics - All Rights Reserved
STMicroelectronics GROUP OF COMPANIES

Australia - Belgium - Brazil - Canada - China - Czech Republic - Finland - France - Germany - Hong Kong - India - Israel - Italy - Japan -
Malaysia - Malta - Morocco - Singapore - Spain - Sweden - Switzerland - United Kingdom - United States.

<http://www.st.com>