

TRQ

➤ MAIN FEATURES

- DIL Pitch Terminals High Sensitivity: 0.14W Nominal Power.
- Conforms to FCC Part 68 1.5KV Surge and Dielectric 1000VAC.
- Monostable or bistable relays Single and double Coil magnet -latching Type available.
- Contact arrangement: 2 Form C
- UL & cUL recognized.



➤ APPLICATIONS

- Telecommunication Equipment, Office Equipment, Security -Alarm Systems, Measuring instruments, Medical Monitoring -Equipment, Audio Visual Equipment, Flight Simulator, Sensor Control.

➤ ORDERING INFORMATION

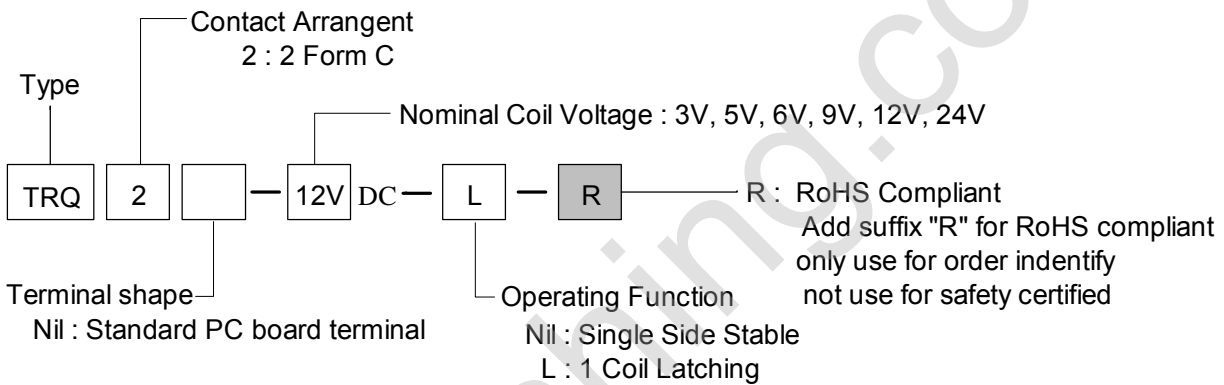

■ DIMENSION (unit:mm)

■ DRILLING (unit:mm)

■ WIRING DIAGRAM

DIP TYPE

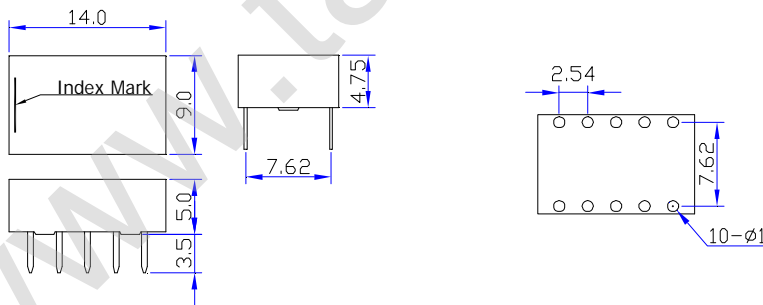

Single Side stable

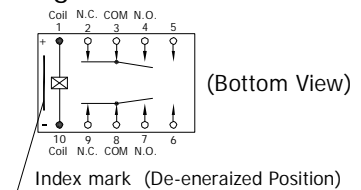

1 Coil latching

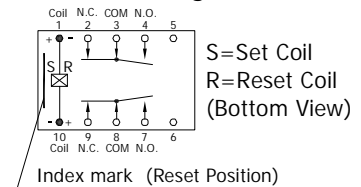

➤ COIL DATA CHART (at 20°C)

Coil Voltage VDC	Coil Voltage (VDC) Rated	Nominal Current (mA)	Coil Resistance (Ω) $\pm 10\%$	Coil Power (W)	Pickup voltage (VDC) Max. (75% of rated voltage)	Release voltage (VDC) Min. (10% of rated voltage)	Coil Voltage (VDC) Max.
Single Side Stable	3	46.7	64.3	0.14	2.25	0.3	7.5
	5	28.1	178	0.14	3.75	0.5	12.5
	6	23.4	257	0.14	4.50	0.6	15.0
	9	15.5	579	0.14	6.75	0.9	22.5
	12	11.7	1028	0.14	9.00	1.2	30.0
1 Coil Latching	24	8.3	2880	0.20	18.0	2.4	48.0
	3	33.3	90	0.10	2.25	-2.25	8.7
	5	20.0	250	0.10	3.75	-3.75	14.5
	6	16.7	360	0.10	4.50	-4.50	17.4
	9	11.1	810	0.10	6.75	-6.75	26.1
	12	8.3	1440	0.10	9.00	-9.00	34.8
	24	6.3	3840	0.15	18.0	-18.0	57.6

➤ CONTACT RATING

Item	Type	TRQ
Contact Capacity Resistive Load (cos Φ =1)		1A / 30VDC 0.5A / 125VAC
Rated Carrying Current		1A
Max. Switching Voltage		220VDC, 250VAC
Max. Switching Current		1A
Max. Switching Power Force		30W, 62.5VA
Referenced Min. Applicable Load		10mA resistive at 10mVDC
Contact Material		Ag Alloy

➤ PERFORMANCE (at initial value)

Item	Type	TRQ
Contact Resistance		50m Ω Max. at initial
Operation Time		Approx. 5msec
Release Time		Approx. 5msec
Dielectric Strength		
Between open contacts		1000VAC (1 minute)
Between coil & contact		1000VAC (1 minute)
Between Contacts Poles		1000VAC (1 minute)
Surge Withstand Voltage		
Between open Contacts		1500V
Between coil & Contacts		1500V
Between Contacts Poles		2500V
Shock Resistance		
Functional		500m/s ² 11ms
Endurance		1000m/s ² 6ms
Vibration Resistance		
Functional		3mm D.A. 10 to 55Hz
Destructive		5mm D.A. 10 to 55Hz
Terminals resistance		5N
Solderability		235°C \pm 2°C, 3 \pm 0.5s
Temperature Range		-40°C ~ 70°C (-40°F ~ 158°F)
Insulation Resistance		1000 M Ω Min. (at 500VDC)
Life Expectancy		
Mechanically		1 \times 10 ⁸ ops. Min. (no load)
Electrically		2 \times 10 ⁵ ops. Min. (1A/30VDC) 1 \times 10 ⁵ ops. Min. (0.5A/125VDC)
Weight		1.5g
UL & cUL		E156521

➤ REFERENCE DATA

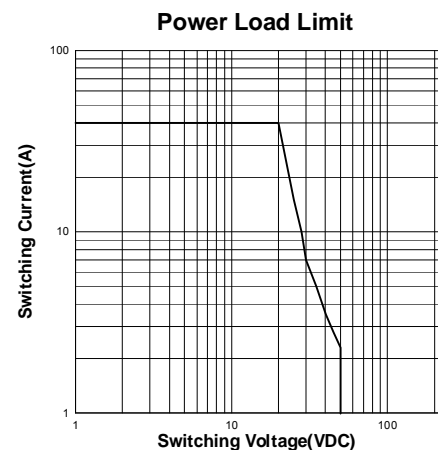
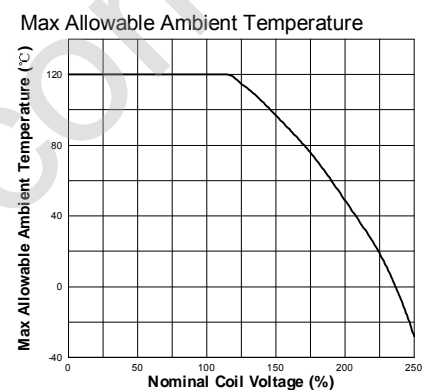

This datasheet for reference and subject to change without notice. Please double check final specification with Tai-Shing. (0939AA08VOL01)