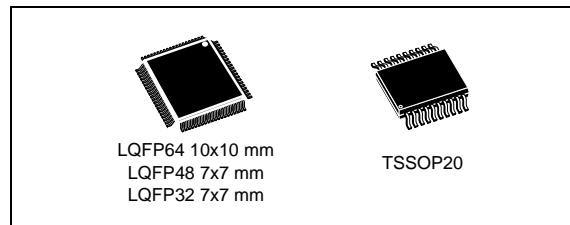


Value-line ARM-based 32-bit MCU with 16 to 64-KB Flash, timers, ADC, communication interfaces, 2.4-3.6 V operation

Datasheet – target specification

## Features

- Core: ARM® 32-bit Cortex™-M0 CPU, frequency up to 48 MHz
- Memories
  - 16 to 64 Kbytes of Flash memory
  - 4 to 8 Kbytes of SRAM with HW parity checking
- CRC calculation unit
- Reset and power management
  - Voltage range: 2.4 V to 3.6 V
  - Power-on/Power down reset (POR/PDR)
  - Low power modes: Sleep, Stop, Standby
- Clock management
  - 4 to 32 MHz crystal oscillator
  - 32 kHz oscillator for RTC with calibration
  - Internal 8 MHz RC with x6 PLL option
  - Internal 40 kHz RC oscillator
- Up to 55 fast I/Os
  - All mappable on external interrupt vectors
  - Up to 36 I/Os with 5 V tolerant capability
- 5-channel DMA controller
- 1 x 12-bit, 1.0 µs ADC (up to 16 channels)
  - Conversion range: 0 to 3.6 V
  - Separate analog supply from 2.4 up to 3.6 V
- Up to 10 timers
  - One 16-bit 7-channel advanced-control timer for 6 channels PWM output, with deadtime generation and emergency stop
  - One 16-bit timer, with up to 4 IC/OC, usable for IR control decoding
  - One 16-bit timer, with 2 IC/OC, 1 OCN, deadtime generation and emergency stop
  - Two 16-bit timers, each with IC/OC and OCN, deadtime generation, emergency stop and modulator gate for IR control
  - One 16-bit timer with 1 IC/OC



- One 16-bit basic timer
- Independent and system watchdog timers
- SysTick timer: 24-bit downcounter
- Calendar RTC with alarm and periodic wakeup from Stop/Standby
- Communication interfaces
  - Up to two I<sup>2</sup>C interfaces: one supporting Fast Mode Plus (1 Mbit/s) with 20 mA current sink
  - Up to two USARTs supporting master synchronous SPI and modem control; one with auto baud rate detection
  - Up to two SPIs (18 Mbit/s) with 4 to 16 programmable bit frame
- Serial wire debug (SWD)

**Table 1. Device summary**

Reference	Part number
STM32F030x4	STM32F030F4
STM32F030x6	STM32F030C6, STM32F030K6
STM32F030x8	STM32F030C8, STM32F030R8

# Contents

<b>1</b>	<b>Introduction</b>	<b>8</b>
<b>2</b>	<b>Description</b>	<b>9</b>
<b>3</b>	<b>Functional overview</b>	<b>12</b>
3.1	ARM® Cortex™-M0 core with embedded Flash and SRAM	12
3.2	Memories	12
3.3	Boot modes	12
3.4	Cyclic redundancy check calculation unit (CRC)	13
3.5	Power management	13
3.5.1	Power supply schemes	13
3.5.2	Power supply supervisors	13
3.5.3	Voltage regulator	13
3.5.4	Low-power modes	14
3.6	Clocks and startup	14
3.7	General-purpose inputs/outputs (GPIOs)	16
3.8	Direct memory access controller (DMA)	16
3.9	Interrupts and events	16
3.9.1	Nested vectored interrupt controller (NVIC)	16
3.9.2	Extended interrupt/event controller (EXTI)	16
3.10	Analog to digital converter (ADC)	17
3.10.1	Temperature sensor	17
3.10.2	Internal voltage reference ( $V_{REFINT}$ )	17
3.11	Timers and watchdogs	18
3.11.1	Advanced-control timer (TIM1)	18
3.11.2	General-purpose timers (TIM3, TIM14..17)	19
3.11.3	Basic timer TIM6	19
3.11.4	Independent watchdog (IWDG)	19
3.11.5	System window watchdog (WWDG)	20
3.11.6	SysTick timer	20
3.12	Real-time clock (RTC)	20
3.13	Inter-integrated circuit interfaces (I <sup>2</sup> C)	21
3.14	Universal synchronous/asynchronous receiver transmitters (USART)	22

3.15	Serial peripheral interface (SPI)	22
3.16	Serial wire debug port (SW-DP)	22
<b>4</b>	<b>Pinouts and pin descriptions</b>	<b>23</b>
<b>5</b>	<b>Memory mapping</b>	<b>33</b>
<b>6</b>	<b>Electrical characteristics</b>	<b>36</b>
6.1	Parameter conditions	36
6.1.1	Minimum and maximum values	36
6.1.2	Typical values	36
6.1.3	Typical curves	36
6.1.4	Loading capacitor	36
6.1.5	Pin input voltage	36
6.1.6	Power supply scheme	37
6.1.7	Current consumption measurement	38
6.2	Absolute maximum ratings	38
6.3	Operating conditions	40
6.3.1	General operating conditions	40
6.3.2	Operating conditions at power-up / power-down	41
6.3.3	Embedded reset and power control block characteristics	41
6.3.4	Embedded reference voltage	41
6.3.5	Supply current characteristics	42
6.3.6	Wakeup time from low-power mode	47
6.3.7	External clock source characteristics	48
6.3.8	Internal clock source characteristics	52
6.3.9	PLL characteristics	53
6.3.10	Memory characteristics	54
6.3.11	EMC characteristics	54
6.3.12	Electrical sensitivity characteristics	56
6.3.13	I/O current injection characteristics	57
6.3.14	I/O port characteristics	57
6.3.15	NRST pin characteristics	62
6.3.16	12-bit ADC characteristics	64
6.3.17	Temperature sensor characteristics	67
6.3.18	Timer characteristics	67
6.3.19	Communication interfaces	69

---

<b>7</b>	<b>Package characteristics</b> .....	<b>74</b>
7.1	Package mechanical data .....	74
7.2	Thermal characteristics .....	83
7.2.1	Reference document .....	83
7.2.2	Selecting the product temperature range .....	83
<b>8</b>	<b>Part numbering</b> .....	<b>86</b>
<b>9</b>	<b>Revision history</b> .....	<b>87</b>

## List of tables

Table 1.	Device summary . . . . .	1
Table 2.	STM32F030x device features and peripheral counts . . . . .	10
Table 3.	Temperature sensor calibration values . . . . .	17
Table 4.	Internal voltage reference calibration values . . . . .	17
Table 5.	Timer feature comparison . . . . .	18
Table 6.	Comparison of I2C analog and digital filters . . . . .	21
Table 7.	STM32F030x I <sup>2</sup> C implementation . . . . .	21
Table 8.	STM32F030x USART implementation . . . . .	22
Table 9.	STM32F030x SPI implementation . . . . .	22
Table 10.	Legend/abbreviations used in the pinout table . . . . .	25
Table 11.	Pin definitions . . . . .	26
Table 12.	Alternate functions selected through GPIOA_AFR registers for port A . . . . .	31
Table 13.	Alternate functions selected through GPIOB_AFR registers for port B . . . . .	32
Table 14.	STM32F030x peripheral register boundary addresses . . . . .	34
Table 15.	Voltage characteristics . . . . .	38
Table 16.	Current characteristics . . . . .	39
Table 17.	Thermal characteristics . . . . .	39
Table 18.	General operating conditions . . . . .	40
Table 19.	Operating conditions at power-up / power-down . . . . .	41
Table 20.	Embedded reset and power control block characteristics . . . . .	41
Table 21.	Embedded internal reference voltage . . . . .	41
Table 22.	Typical and maximum current consumption from V <sub>DD</sub> supply at V <sub>DD</sub> = 3.6 . . . . .	43
Table 23.	Typical and maximum current consumption from the V <sub>DDA</sub> supply . . . . .	43
Table 24.	Typical and maximum V <sub>DD</sub> consumption in Stop and Standby modes . . . . .	44
Table 25.	Typical and maximum V <sub>DDA</sub> consumption in Stop and Standby modes . . . . .	44
Table 26.	Typical current consumption in Run mode, code with data processing running from Flash . . . . .	45
Table 27.	Switching output I/O current consumption . . . . .	47
Table 28.	Low-power mode wakeup timings . . . . .	47
Table 29.	High-speed external user clock characteristics . . . . .	48
Table 30.	Low-speed external user clock characteristics . . . . .	49
Table 31.	HSE oscillator characteristics . . . . .	50
Table 32.	LSE oscillator characteristics (f <sub>LSE</sub> = 32.768 kHz) . . . . .	51
Table 33.	HSI oscillator characteristics . . . . .	52
Table 34.	HSI14 oscillator characteristics . . . . .	53
Table 35.	LSI oscillator characteristics . . . . .	53
Table 36.	PLL characteristics . . . . .	54
Table 37.	Flash memory characteristics . . . . .	54
Table 38.	Flash memory endurance and data retention . . . . .	54
Table 39.	EMS characteristics . . . . .	55
Table 40.	EMI characteristics . . . . .	56
Table 41.	ESD absolute maximum ratings . . . . .	56
Table 42.	Electrical sensitivities . . . . .	56
Table 43.	I/O current injection susceptibility . . . . .	57
Table 44.	I/O static characteristics . . . . .	57
Table 45.	Output voltage characteristics . . . . .	60
Table 46.	I/O AC characteristics . . . . .	61
Table 47.	NRST pin characteristics . . . . .	62

Table 48.	ADC characteristics . . . . .	64
Table 49.	$R_{AIN}$ max for $f_{ADC} = 14$ MHz . . . . .	65
Table 50.	ADC accuracy . . . . .	65
Table 51.	TS characteristics . . . . .	67
Table 52.	TIMx characteristics . . . . .	67
Table 53.	IWDG min/max timeout period at 40 kHz (LSI) . . . . .	68
Table 54.	WWDG min-max timeout value @48 MHz (PCLK) . . . . .	68
Table 55.	I2C characteristics . . . . .	69
Table 56.	I2C analog filter characteristics . . . . .	70
Table 57.	SPI characteristics . . . . .	71
Table 58.	LQFP64 – 10 x 10 mm 64 pin low-profile quad flat package mechanical data . . . . .	75
Table 59.	LQFP48 – 7 x 7 mm, 48-pin low-profile quad flat package mechanical data . . . . .	77
Table 60.	LQFP32 – 7 x 7mm 32-pin low-profile quad flat package mechanical data . . . . .	79
Table 61.	TSSOP20 – 20-pin thin shrink small outline package mechanical data . . . . .	81
Table 62.	Package thermal characteristics . . . . .	83
Table 63.	Ordering information scheme . . . . .	86
Table 64.	Document revision history . . . . .	87

## List of figures

Figure 1.	Block diagram . . . . .	11
Figure 2.	Clock tree . . . . .	15
Figure 3.	LQFP64 64-pin package pinout . . . . .	23
Figure 4.	LQFP48 48-pin package pinout . . . . .	24
Figure 5.	LQFP32 32-pin package pinout . . . . .	24
Figure 6.	TSSOP20 package pinout . . . . .	25
Figure 7.	STM32F030x memory map . . . . .	33
Figure 8.	Pin loading conditions . . . . .	36
Figure 9.	Pin input voltage . . . . .	36
Figure 10.	Power supply scheme . . . . .	37
Figure 11.	Current consumption measurement scheme . . . . .	38
Figure 12.	High-speed external clock source AC timing diagram . . . . .	48
Figure 13.	Low-speed external clock source AC timing diagram . . . . .	49
Figure 14.	Typical application with an 8 MHz crystal . . . . .	51
Figure 15.	Typical application with a 32.768 kHz crystal . . . . .	52
Figure 16.	TC and TTa I/O input characteristics . . . . .	59
Figure 17.	Five volt tolerant (FT and FTf) I/O input characteristics . . . . .	59
Figure 18.	I/O AC characteristics definition . . . . .	62
Figure 19.	Recommended NRST pin protection . . . . .	63
Figure 20.	ADC accuracy characteristics . . . . .	66
Figure 21.	Typical connection diagram using the ADC . . . . .	66
Figure 22.	I <sup>2</sup> C bus AC waveforms and measurement circuit . . . . .	70
Figure 23.	SPI timing diagram - slave mode and CPHA = 0 . . . . .	72
Figure 24.	SPI timing diagram - slave mode and CPHA = 1 . . . . .	72
Figure 25.	SPI timing diagram - master mode . . . . .	73
Figure 26.	LQFP64 – 10 x 10 mm 64 pin low-profile quad flat package outline . . . . .	75
Figure 27.	LQFP64 recommended footprint . . . . .	76
Figure 28.	LQFP48 – 7 x 7 mm, 48 pin low-profile quad flat package outline . . . . .	77
Figure 29.	LQFP48 recommended footprint . . . . .	78
Figure 30.	LQFP32 – 7 x 7mm 32-pin low-profile quad flat package outline . . . . .	79
Figure 31.	LQFP32 recommended footprint . . . . .	80
Figure 32.	TSSOP20 - 20-pin thin shrink small outline . . . . .	81
Figure 33.	TSSOP20 recommended footprint . . . . .	82
Figure 34.	LQFP64 P <sub>D</sub> max vs. T <sub>A</sub> . . . . .	85

# 1 Introduction

This datasheet provides the ordering information and mechanical device characteristics of the STM32F030x microcontrollers.

This STM32F030x4, STM32F030x6, and STM32F030x8 datasheet should be read in conjunction with the STM32F0xxxx reference manual (RM0091). The reference manual is available from the STMicroelectronics website [www.st.com](http://www.st.com).

For information on the ARM Cortex™-M0 core, please refer to the Cortex™-M0 Technical Reference Manual, available from the [www.arm.com](http://www.arm.com) website at the following address:  
<http://infocenter.arm.com/help/index.jsp?topic=/com.arm.doc.ddi0432c/index.html>.





## 2 Description

The STM32F030x microcontroller incorporates the high-performance ARM Cortex™-M0 32-bit RISC core operating at a 48 MHz frequency, high-speed embedded memories (up to 64 Kbytes of Flash memory and up to 8 Kbytes of SRAM), and an extensive range of enhanced peripherals and I/Os. All devices offer standard communication interfaces (up to two I<sup>2</sup>Cs, up to two SPIs, and up to two USARTs), one 12-bit ADC, up to 6 general-purpose 16-bit timers and an advanced-control PWM timer.

The STM32F030x microcontroller operates in the -40 to +85 °C temperature range, from a 2.4 to 3.6 V power supply. A comprehensive set of power-saving modes allows the design of low-power applications.

The STM32F030x microcontroller includes devices in four different packages ranging from 20 pins to 64 pins. Depending on the device chosen, different sets of peripherals are included. The description below provides an overview of the complete range of STM32F030x peripherals proposed.

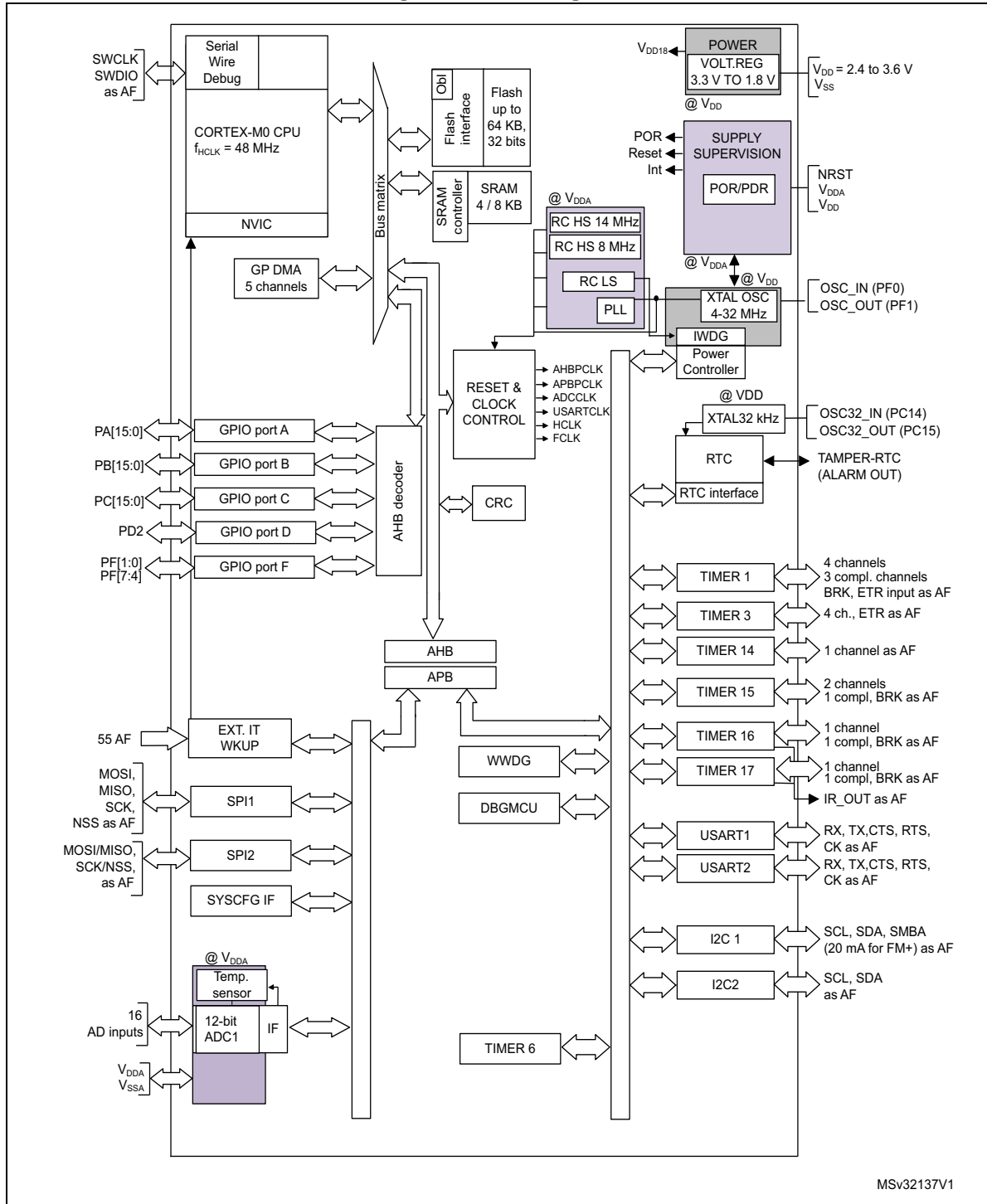
These features make the STM32F030x microcontroller suitable for a wide range of applications such as application control and user interfaces, handheld equipment, A/V receivers and digital TV, PC peripherals, gaming platforms, e-bikes, consumer appliances, printers, scanners, alarm systems, video intercoms, and HVACs.

Table 2. STM32F030x device features and peripheral counts

Peripheral		STM32F030F4	STM32F030K6	STM32F030C6/C8		STM32F030R8
Flash (Kbytes)		16	32	32	64	64
SRAM (Kbytes)		4	4	4	8	8
Timers	Advanced control	1 (16-bit)				
	General purpose	4 (16-bit) <sup>(1)</sup>	4 (16-bit) <sup>(1)</sup>	4 (16-bit) <sup>(1)</sup>	5 (16-bit)	5 (16-bit)
	Basic	-	-	-	1 (16-bit)	1 (16-bit)
Comm. interfaces	SPI	1 <sup>(2)</sup>	1 <sup>(2)</sup>	1 <sup>(2)</sup>	2	2
	I <sup>2</sup> C	1 <sup>(3)</sup>	1 <sup>(3)</sup>	1 <sup>(3)</sup>	2	2
	USART	1 <sup>(4)</sup>	1 <sup>(4)</sup>	1 <sup>(4)</sup>	2	2
12-bit synchronized ADC (number of channels)		1 (11 channels)	1 (12 channels)	1 (12 channels)		1 (18 channels)
GPIOs		15	26	39		55
Max. CPU frequency		48 MHz				
Operating voltage		2.4 to 3.6 V				
Operating temperature		Ambient operating temperature: -40 °C to 85 °C				
Packages		TSSOP20	LQFP32	LQFP48		LQFP64

1. TIM15 is not present.
2. SPI2 is not present.
3. I2C2 is not present.
4. USART2 is not present.

Figure 1. Block diagram



1. TIMER6, TIMER15, SPI2, USART2 and I2C2 are available on STM32F030x8 devices only.

## 3 Functional overview

### 3.1 ARM<sup>®</sup> Cortex<sup>™</sup>-M0 core with embedded Flash and SRAM

The ARM Cortex<sup>™</sup>-M0 processor is the latest generation of ARM processors for embedded systems. It has been developed to provide a low-cost platform that meets the needs of MCU implementation, with a reduced pin count and low-power consumption, while delivering outstanding computational performance and an advanced system response to interrupts.

The ARM Cortex<sup>™</sup>-M0 32-bit RISC processor features exceptional code-efficiency, delivering the high-performance expected from an ARM core in the memory size usually associated with 8- and 16-bit devices.

The STM32F0xx family has an embedded ARM core and is therefore compatible with all ARM tools and software.

*Figure 1* shows the general block diagram of the device family.

### 3.2 Memories

The device has the following features:

- Up to 8 Kbytes of embedded SRAM accessed (read/write) at CPU clock speed with 0 wait states and featuring embedded parity checking with exception generation for fail-critical applications.
- The non-volatile memory is divided into two arrays:
  - 16 to 64 Kbytes of embedded Flash memory for programs and data
  - Option bytes

The option bytes are used to write-protect the memory (with 4 KB granularity) and/or readout-protect the whole memory with the following options:

- Level 0: no readout protection
- Level 1: memory readout protection, the Flash memory cannot be read from or written to if either debug features are connected or boot in RAM is selected
- Level 2: chip readout protection, debug features (Cortex-M0 serial wire) and boot in RAM selection disabled

### 3.3 Boot modes

At startup, the boot pin and boot selector option bit are used to select one of three boot options:

- Boot from User Flash
- Boot from System Memory
- Boot from embedded SRAM

The boot loader is located in System Memory. It is used to reprogram the Flash memory by using USART on pins PA14/PA15 or PA9/PA10.

## 3.4 Cyclic redundancy check calculation unit (CRC)

The CRC (cyclic redundancy check) calculation unit is used to get a CRC code from a 32-bit data word and a CRC-32 (Ethernet) polynomial.

Among other applications, CRC-based techniques are used to verify data transmission or storage integrity. In the scope of the EN/IEC 60335-1 standard, they offer a means of verifying the Flash memory integrity. The CRC calculation unit helps compute a signature of the software during runtime, to be compared with a reference signature generated at link-time and stored at a given memory location.

## 3.5 Power management

### 3.5.1 Power supply schemes

- $V_{DD} = 2.4$  to  $3.6$  V: external power supply for I/Os and the internal regulator. Provided externally through  $V_{DD}$  pins.
- $V_{DDA} = 2.4$  to  $3.6$  V: external analog power supply for ADC, Reset blocks, RCs and PLL. The  $V_{DDA}$  voltage level must be always greater or equal to the  $V_{DD}$  voltage level and must be provided first.

For more details on how to connect power pins, refer to [Figure 10: Power supply scheme](#).

### 3.5.2 Power supply supervisors

The device has integrated power-on reset (POR) and power-down reset (PDR) circuits. They are always active, and ensure proper operation above a threshold of 2 V. The device remains in reset mode when the monitored supply voltage is below a specified threshold,  $V_{POR/PDR}$ , without the need for an external reset circuit.

- The POR monitors only the  $V_{DD}$  supply voltage. During the startup phase it is required that  $V_{DDA}$  should arrive first and be greater than or equal to  $V_{DD}$ .
- The PDR monitors both the  $V_{DD}$  and  $V_{DDA}$  supply voltages, however the  $V_{DDA}$  power supply supervisor can be disabled (by programming a dedicated Option bit) to reduce the power consumption if the application design ensures that  $V_{DDA}$  is higher than or equal to  $V_{DD}$ .

### 3.5.3 Voltage regulator

The regulator has three operating modes: main (MR), low power (LPR) and power down.

- MR is used in normal operating mode (Run)
- LPR can be used in Stop mode where the power demand is reduced
- Power down is used in Standby mode: the regulator output is in high impedance: the kernel circuitry is powered down, inducing zero consumption (but the contents of the registers and SRAM are lost)

This regulator is always enabled after reset. It is disabled in Standby mode, providing high impedance output.

### 3.5.4 Low-power modes

The STM32F030x microcontroller supports three low-power modes to achieve the best compromise between low power consumption, short startup time and available wakeup sources:

- **Sleep mode**

In Sleep mode, only the CPU is stopped. All peripherals continue to operate and can wake up the CPU when an interrupt/event occurs.

- **Stop mode**

Stop mode achieves very low power consumption while retaining the content of SRAM and registers. All clocks in the 1.8 V domain are stopped, the PLL, the HSI RC and the HSE crystal oscillators are disabled. The voltage regulator can also be put either in normal or in low power mode.

The device can be woken up from Stop mode by any of the EXTI lines. The EXTI line source can be one of the 16 external lines or the RTC alarm.

- **Standby mode**

The Standby mode is used to achieve the lowest power consumption. The internal voltage regulator is switched off so that the entire 1.8 V domain is powered off. The PLL, the HSI RC and the HSE crystal oscillators are also switched off. After entering Standby mode, SRAM and register contents are lost except for the Standby circuitry.

The device exits Standby mode when an external reset (NRST pin), an IWDG reset, a rising edge on the WKUP pins, or an RTC alarm occurs.

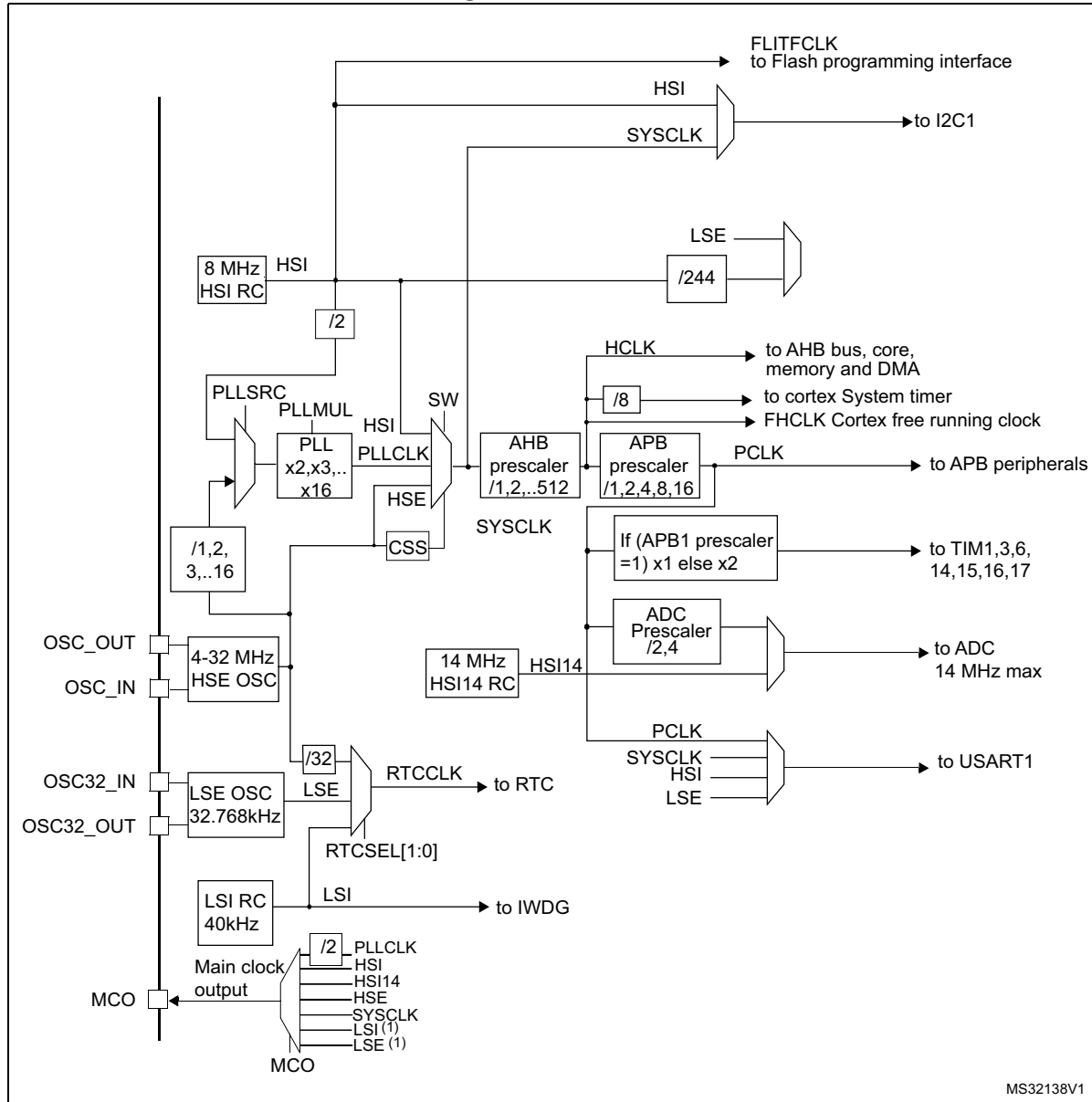
*Note: The RTC, the IWDG, and the corresponding clock sources are not stopped by entering Stop or Standby mode.*

## 3.6 Clocks and startup

System clock selection is performed on startup, however the internal RC 8 MHz oscillator is selected as default CPU clock on reset. An external 4-32 MHz clock can be selected, in which case it is monitored for failure. If failure is detected, the system automatically switches back to the internal RC oscillator. A software interrupt is generated if enabled. Similarly, full interrupt management of the PLL clock entry is available when necessary (for example on failure of an indirectly used external crystal, resonator or oscillator).

Several prescalers allow the application to configure the frequency of the AHB and the APB domains. The maximum frequency of the AHB and the APB domains is 48 MHz.

Figure 2. Clock tree



MS32138V1

1. LSI/LSE is not available on STM32F030x8 devices.

### 3.7 General-purpose inputs/outputs (GPIOs)

Each of the GPIO pins can be configured by software as output (push-pull or open-drain), as input (with or without pull-up or pull-down) or as peripheral alternate function. Most of the GPIO pins are shared with digital or analog alternate functions.

The I/O configuration can be locked if needed following a specific sequence in order to avoid spurious writing to the I/Os registers.

### 3.8 Direct memory access controller (DMA)

The 5-channel general-purpose DMAs manage memory-to-memory, peripheral-to-memory and memory-to-peripheral transfers.

The DMA supports circular buffer management, removing the need for user code intervention when the controller reaches the end of the buffer.

Each channel is connected to dedicated hardware DMA requests, with support for software trigger on each channel. Configuration is made by software and transfer sizes between source and destination are independent.

DMA can be used with the main peripherals: SPI, I2C, USART, all TIMx timers (except TIM14) and ADC.

### 3.9 Interrupts and events

#### 3.9.1 Nested vectored interrupt controller (NVIC)

The STM32F0xx family embeds a nested vectored interrupt controller able to handle up to 32 maskable interrupt channels (not including the 16 interrupt lines of Cortex™-M0) and 4 priority levels.

- Closely coupled NVIC gives low latency interrupt processing
- Interrupt entry vector table address passed directly to the core
- Closely coupled NVIC core interface
- Allows early processing of interrupts
- Processing of late arriving higher priority interrupts
- Support for tail-chaining
- Processor state automatically saved
- Interrupt entry restored on interrupt exit with no instruction overhead

This hardware block provides flexible interrupt management features with minimal interrupt latency.

#### 3.9.2 Extended interrupt/event controller (EXTI)

The extended interrupt/event controller consists of 24 edge detector lines used to generate interrupt/event requests and wake-up the system. Each line can be independently configured to select the trigger event (rising edge, falling edge, both) and can be masked independently. A pending register maintains the status of the interrupt requests. The EXTI can detect an external line with a pulse width shorter than the internal clock period. Up to 55 GPIOs can be connected to the 16 external interrupt lines.



## 3.10 Analog to digital converter (ADC)

The 12-bit analog to digital converter has up to 16 external and 2 internal (temperature sensor/voltage reference measurement) channels and performs conversions in single-shot or scan modes. In scan mode, automatic conversion is performed on a selected group of analog inputs.

The ADC can be served by the DMA controller.

An analog watchdog feature allows very precise monitoring of the converted voltage of one, some or all selected channels. An interrupt is generated when the converted voltage is outside the programmed thresholds.

### 3.10.1 Temperature sensor

The temperature sensor (TS) generates a voltage  $V_{SENSE}$  that varies linearly with temperature.

The temperature sensor is internally connected to the ADC\_IN16 input channel which is used to convert the sensor output voltage into a digital value.

The sensor provides good linearity but it has to be calibrated to obtain good overall accuracy of the temperature measurement. As the offset of the temperature sensor varies from chip to chip due to process variation, the uncalibrated internal temperature sensor is suitable for applications that detect temperature changes only.

To improve the accuracy of the temperature sensor measurement, each device is individually factory-calibrated by ST. The temperature sensor factory calibration data are stored by ST in the system memory area, accessible in read-only mode.

**Table 3. Temperature sensor calibration values**

Calibration value name	Description	Memory address
TS_CAL1	TS ADC raw data acquired at temperature of 30 °C, $V_{DDA} = 3.3$ V	0x1FFF F7B8 - 0x1FFF F7B9
TS_CAL2	TS ADC raw data acquired at temperature of 110 °C $V_{DDA} = 3.3$ V	0x1FFF F7C2 - 0x1FFF F7C3

### 3.10.2 Internal voltage reference ( $V_{REFINT}$ )

The internal voltage reference ( $V_{REFINT}$ ) provides a stable (bandgap) voltage output for the ADC.  $V_{REFINT}$  is internally connected to the ADC\_IN17 input channel. The precise voltage of  $V_{REFINT}$  is individually measured for each part by ST during production test and stored in the system memory area. It is accessible in read-only mode.

**Table 4. Internal voltage reference calibration values**

Calibration value name	Description	Memory address
VREFINT_CAL	Raw data acquired at temperature of 30 °C $V_{DDA} = 3.3$ V	0x1FFF F7BA - 0x1FFF F7BB

### 3.11 Timers and watchdogs

Devices of the STM32F0xx family include up to six general-purpose timers, one basic timer and an advanced control timer.

[Table 5](#) compares the features of the advanced-control, general-purpose and basic timers.

**Table 5. Timer feature comparison**

Timer type	Timer	Counter resolution	Counter type	Prescaler factor	DMA request generation	Capture/compare channels	Complementary outputs
Advanced control	TIM1	16-bit	Up, down, up/down	Any integer between 1 and 65536	Yes	4	Yes
General purpose	TIM3	16-bit	Up, down, up/down	Any integer between 1 and 65536	Yes	4	No
	TIM14	16-bit	Up	Any integer between 1 and 65536	No	1	No
	TIM15 <sup>(1)</sup>	16-bit	Up	Any integer between 1 and 65536	Yes	2	Yes
	TIM16, TIM17	16-bit	Up	Any integer between 1 and 65536	Yes	1	Yes
Basic	TIM6 <sup>(1)</sup>	16-bit	Up	Any integer between 1 and 65536	Yes	0	No

1. Available on STM32F030x8 devices only.

#### 3.11.1 Advanced-control timer (TIM1)

The advanced-control timer (TIM1) can be seen as a three-phase PWM multiplexed on 6 channels. It has complementary PWM outputs with programmable inserted dead times. It can also be seen as a complete general-purpose timer. The 4 independent channels can be used for:

- Input capture
- Output compare
- PWM generation (edge or center-aligned modes)
- One-pulse mode output

If configured as a standard 16-bit timer, it has the same features as the TIMx timer. If configured as the 16-bit PWM generator, it has full modulation capability (0-100%).

The counter can be frozen in debug mode.

Many features are shared with those of the standard timers which have the same architecture. The advanced control timer can therefore work together with the other timers via the Timer Link feature for synchronization or event chaining.

### 3.11.2 General-purpose timers (TIM3, TIM14..17)

There are five synchronizable general-purpose timers embedded in the STM32F030x devices (see [Table 5](#) for differences). Each general-purpose timer can be used to generate PWM outputs, or as simple time base.

#### TIM3

STM32F030x devices feature a synchronizable 4-channel general-purpose timer based on a 16-bit auto-reload up/downcounter and a 16-bit prescaler. TIM3 features 4 independent channels for input capture/output compare, PWM or one-pulse mode output. This gives up to 12 input captures/output compares/PWMs on the largest packages.

The TIM3 general-purpose timer can work with the TIM1 advanced-control timer via the Timer Link feature for synchronization or event chaining.

It provides independent DMA request generation.

The TIM3 timer is capable of handling quadrature (incremental) encoder signals and the digital outputs from 1 to 3 hall-effect sensors.

Its counter can be frozen in debug mode.

#### TIM14

This timer is based on a 16-bit auto-reload upcounter and a 16-bit prescaler.

TIM14 features one single channel for input capture/output compare, PWM or one-pulse mode output.

Its counter can be frozen in debug mode.

#### TIM15, TIM16 and TIM17

These timers are based on a 16-bit auto-reload upcounter and a 16-bit prescaler.

TIM15 has two independent channels, whereas TIM16 and TIM17 feature one single channel for input capture/output compare, PWM or one-pulse mode output.

The TIM15, TIM16 and TIM17 timers can work together, and TIM15 can also operate with TIM1 via the Timer Link feature for synchronization or event chaining.

TIM15 can be synchronized with TIM16 and TIM17.

TIM15, TIM16, and TIM17 have a complementary output with dead-time generation and independent DMA request generation.

Their counters can be frozen in debug mode.

### 3.11.3 Basic timer TIM6

This timer is mainly used as a generic 16-bit time base.

### 3.11.4 Independent watchdog (IWDG)

The independent watchdog is based on an 8-bit prescaler and 12-bit downcounter with user-defined refresh window. It is clocked from an independent 40 kHz internal RC and as it operates independently from the main clock, it can operate in Stop and Standby modes. It can be used either as a watchdog to reset the device when a problem occurs, or as a free

running timer for application timeout management. It is hardware or software configurable through the option bytes. The counter can be frozen in debug mode.

### 3.11.5 System window watchdog (WWDG)

The system window watchdog is based on a 7-bit downcounter that can be set as free running. It can be used as a watchdog to reset the device when a problem occurs. It is clocked from the APB clock (PCLK). It has an early warning interrupt capability and the counter can be frozen in debug mode.

### 3.11.6 SysTick timer

This timer is dedicated to real-time operating systems, but could also be used as a standard down counter. It features:

- A 24-bit down counter
- Autoreload capability
- Maskable system interrupt generation when the counter reaches 0
- Programmable clock source (HCLK or HCLK/8)

## 3.12 Real-time clock (RTC)

The RTC is an independent BCD timer/counter. Its main features are the following:

- Calendar with subsecond, seconds, minutes, hours (12 or 24 format), week day, date, month, year, in BCD (binary-coded decimal) format
- Automatically correction for 28, 29 (leap year), 30, and 31 day of the month
- Programmable alarm with wake up from Stop and Standby mode capability
- On-the-fly correction from 1 to 32767 RTC clock pulses. This can be used to synchronize it with a master clock.
- Digital calibration circuit with 1 ppm resolution, to compensate for quartz crystal inaccuracy
- 2 anti-tamper detection pins with programmable filter. The MCU can be woken up from Stop and Standby modes on tamper event detection.
- Timestamp feature which can be used to save the calendar content. This function can be triggered by an event on the timestamp pin, or by a tamper event. The MCU can be woken up from Stop and Standby modes on timestamp event detection.
- Periodic wakeup from Stop/Standby
- Reference clock detection: a more precise second source clock (50 or 60 Hz) can be used to enhance the calendar precision.

The RTC clock sources can be:

- A 32.768 kHz external crystal
- A resonator or oscillator
- The internal low-power RC oscillator (typical frequency of 40 kHz)
- The high-speed external clock divided by 32

### 3.13 Inter-integrated circuit interfaces (I<sup>2</sup>C)

Up to two I<sup>2</sup>C interfaces (I2C1 and I2C2) can operate in multimaster or slave modes. Both can support Standard mode (up to 100 kbit/s) or Fast mode (up to 400 kbit/s). I2C1 also supports Fast Mode Plus (up to 1 Mbit/s) with 20 mA output drive.

Both support 7-bit and 10-bit addressing modes, multiple 7-bit slave addresses (2 addresses, 1 with configurable mask). They also include programmable analog and digital noise filters.

**Table 6. Comparison of I2C analog and digital filters**

	Analog filter	Digital filter
Pulse width of suppressed spikes	≥ 50 ns	Programmable length from 1 to 15 I2C peripheral clocks
Benefits	Available in Stop mode	1. Extra filtering capability vs. standard requirements. 2. Stable length
Drawbacks	Variations depending on temperature, voltage, process	Wakeup from Stop on address match is not available when digital filter is enabled.

In addition, I2C1 provides hardware support for SMBUS 2.0 and PMBUS 1.1: ARP capability, Host notify protocol, hardware CRC (PEC) generation/verification, timeouts verifications and ALERT protocol management.

The I2C interfaces can be served by the DMA controller.

Refer to [Table 7](#) for the differences between I2C1 and I2C2.

**Table 7. STM32F030x I<sup>2</sup>C implementation**

I2C features <sup>(1)</sup>	I2C1	I2C2
7-bit addressing mode	X	X
10-bit addressing mode	X	X
Standard mode (up to 100 kbit/s)	X	X
Fast mode (up to 400 kbit/s)	X	X
Fast Mode Plus with 20 mA output drive I/Os (up to 1 Mbit/s)	X	-
SMBus	X	-

1. X = supported.

### 3.14 Universal synchronous/asynchronous receiver transmitters (USART)

The device embeds up to two universal synchronous/asynchronous receiver transmitters (USART1 and USART2), which communicate at speeds of up to 6 Mbit/s.

They provide hardware management of the CTS and RTS signals, multiprocessor communication mode, master synchronous communication and single-wire half-duplex communication mode. The USART1 supports also auto baud rate feature.

The USART interfaces can be served by the DMA controller.

Refer to [Table 8](#) for the differences between USART1 and USART2.

**Table 8. STM32F030x USART implementation**

USART modes/features <sup>(1)</sup>	USART1	USART2
Hardware flow control for modem	X	X
Continuous communication using DMA	X	X
Multiprocessor communication	X	X
Synchronous mode	X	X
Single-wire half-duplex communication	X	X
Receiver timeout interrupt	X	-
Auto baud rate detection	X	-

1. X = supported.

### 3.15 Serial peripheral interface (SPI)

Up to two SPIs are able to communicate up to 18 Mbits/s in slave and master modes in full-duplex and half-duplex communication modes. The 3-bit prescaler gives 8 master mode frequencies and the frame size is configurable from 4 bits to 16 bits.

Refer to [Table 9](#) for the differences between SPI1 and SPI2.

**Table 9. STM32F030x SPI implementation**

SPI features <sup>(1)</sup>	SPI1	SPI2
Hardware CRC calculation	X	X
Rx/Tx FIFO	X	X
NSS pulse mode	X	X
TI mode	X	X

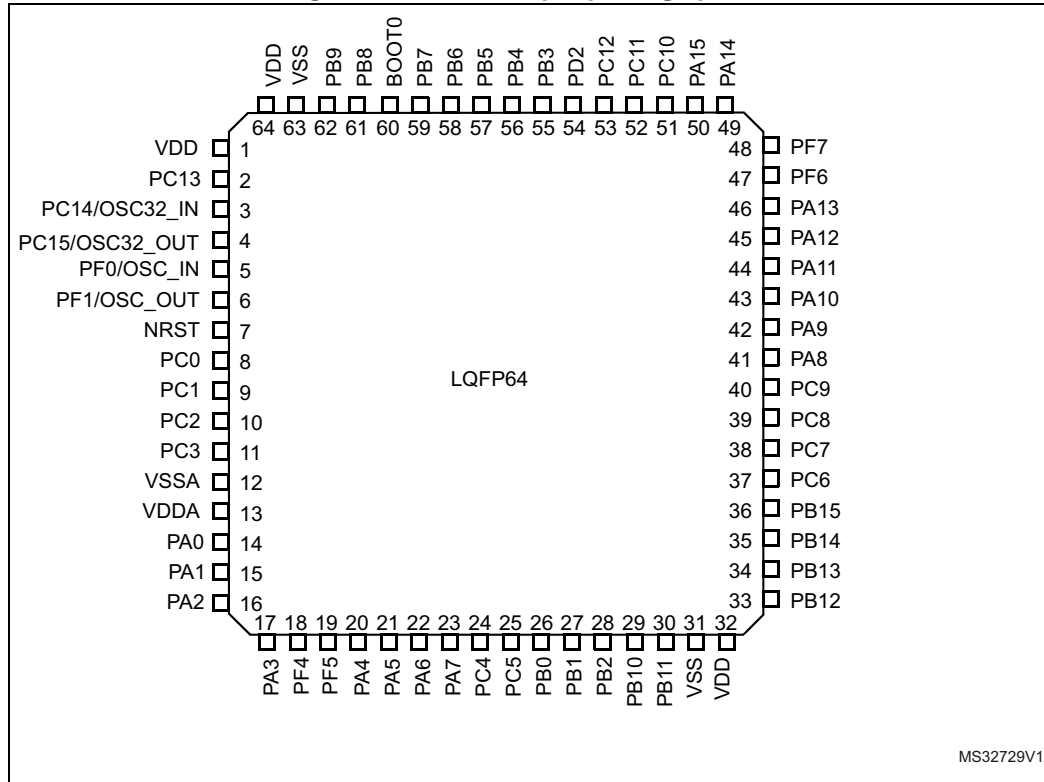
1. X = supported.

### 3.16 Serial wire debug port (SW-DP)

An ARM SW-DP interface is provided to allow a serial wire debugging tool to be connected to the MCU.

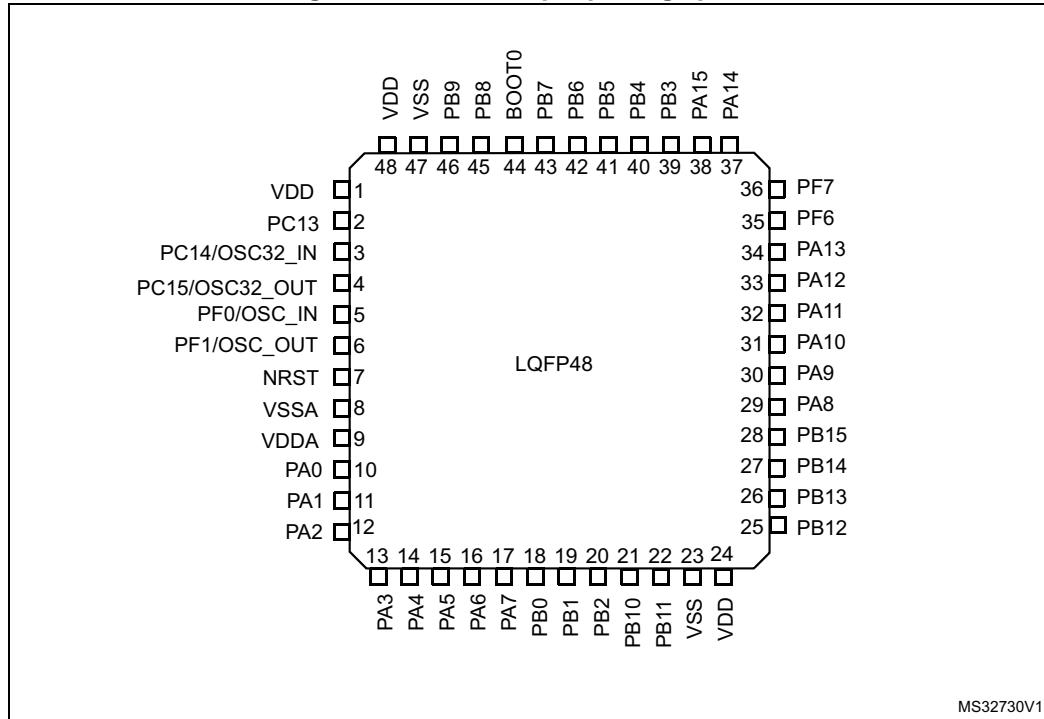
## 4 Pinouts and pin descriptions

Figure 3. LQFP64 64-pin package pinout



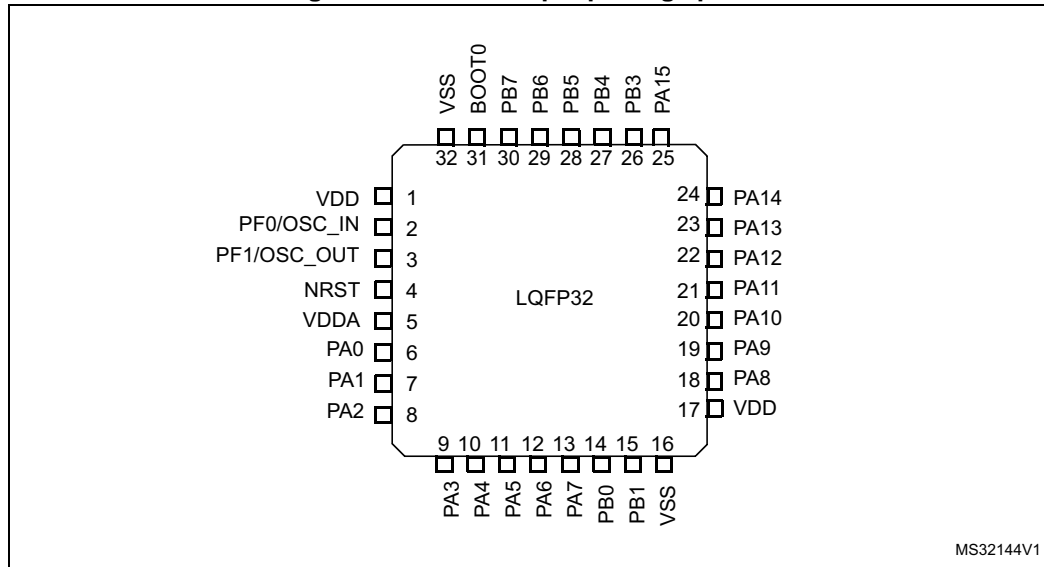
1. The above figure shows the package top view.

Figure 4. LQFP48 48-pin package pinout



1. The above figure shows the package top view.

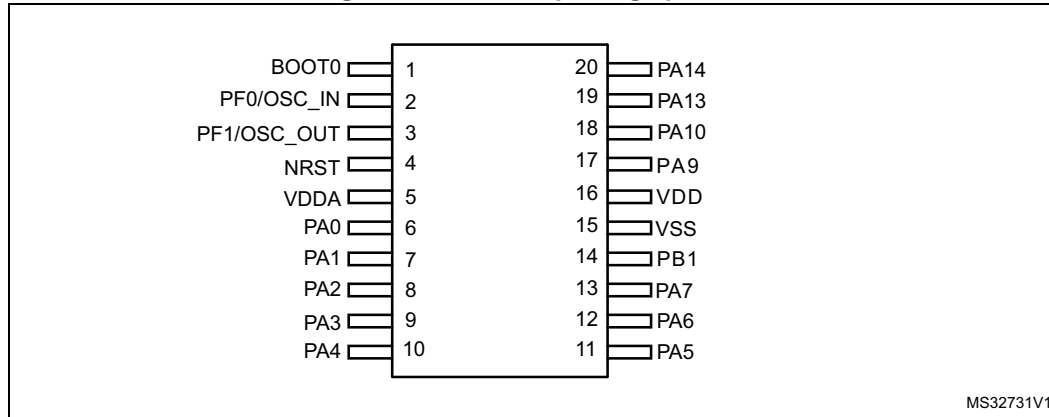
Figure 5. LQFP32 32-pin package pinout



1. The above figure shows the package top view.



Figure 6. TSSOP20 package pinout



1. The above figure shows the package top view.

Table 10. Legend/abbreviations used in the pinout table

Name	Abbreviation	Definition
Pin name	Unless otherwise specified in brackets below the pin name, the pin function during and after reset is the same as the actual pin name	
Pin type	S	Supply pin
	I	Input only pin
	I/O	Input / output pin
I/O structure	FT	5 V tolerant I/O
	FTf	5 V tolerant I/O, FM+ capable
	TTa	3.3 V tolerant I/O directly connected to ADC
	TC	Standard 3.3V I/O
	B	Dedicated BOOT0 pin
	RST	Bidirectional reset pin with embedded weak pull-up resistor
Notes	Unless otherwise specified by a note, all I/Os are set as floating inputs during and after reset.	
Pin functions	Alternate functions	Functions selected through GPIOx_AFR registers
	Additional functions	Functions directly selected/enabled through peripheral registers

Table 11. Pin definitions

Pin number				Pin name (function after reset)	Pin type	I/O structure	Notes	Pin functions	
LQFP64	LQFP48	LQFP32	TSSOP20					Alternate functions	Additional functions
1	1	-	-	VDD	S			Complementary power supply	
2	2	-	-	PC13	I/O	TC	(1)	-	RTC_TAMP1, RTC_TS, RTC_OUT, WKUP2
3	3	-	-	PC14-OSC32_IN (PC14)	I/O	TC	(1)	-	OSC32_IN
4	4	-	-	PC15-OSC32_OUT (PC15)	I/O	TC	(1)	-	OSC32_OUT
5	5	2	2	PF0-OSC_IN (PF0)	I/O	FT		-	OSC_IN
6	6	3	3	PF1-OSC_OUT (PF1)	I/O	FT		-	OSC_OUT
7	7	4	4	NRST	I/O	RST		Device reset input / internal reset output (active low)	
8	-	-	-	PC0	I/O	TTa		EVENTOUT	ADC_IN10
9	-	-	-	PC1	I/O	TTa		EVENTOUT	ADC_IN11
10	-	-	-	PC2	I/O	TTa		EVENTOUT	ADC_IN12
11	-	-	-	PC3	I/O	TTa		EVENTOUT	ADC_IN13
12	8	-	-	VSSA	S			Analog ground	
13	9	5	5	VDDA	S			Analog power supply	
14	10	6	6	PA0	I/O	TTa		USART1_CTS <sup>(2)</sup> , USART2_CTS <sup>(3)</sup>	ADC_IN0, RTC_TAMP2, WKUP1
15	11	7	7	PA1	I/O	TTa		USART1_RTS <sup>(2)</sup> , USART2_RTS <sup>(3)</sup> , EVENTOUT	ADC_IN1
16	12	8	8	PA2	I/O	TTa		USART1_TX <sup>(2)</sup> , USART2_TX <sup>(3)</sup> , TIM15_CH1 <sup>(3)</sup>	ADC_IN2
17	13	9	9	PA3	I/O	TTa		USART1_RX <sup>(2)</sup> , USART2_RX <sup>(3)</sup> , TIM15_CH2 <sup>(3)</sup>	ADC_IN3
18	-	-	-	PF4	I/O	FT		EVENTOUT	-
19	-	-	-	PF5	I/O	FT		EVENTOUT	-

Table 11. Pin definitions (continued)

Pin number				Pin name (function after reset)	Pin type	I/O structure	Notes	Pin functions	
LQFP64	LQFP48	LQFP32	TSSOP20					Alternate functions	Additional functions
20	14	10	10	PA4	I/O	TTa		SPI1_NSS, USART1_CK <sup>(2)</sup> , USART2_CK <sup>(3)</sup> , TIM14_CH1	ADC_IN4
21	15	11	11	PA5	I/O	TTa		SPI1_SCK	ADC_IN5
22	16	12	12	PA6	I/O	TTa		SPI1_MISO, TIM3_CH1, TIM1_BKIN, TIM16_CH1, EVENTOUT	ADC_IN6
23	17	13	13	PA7	I/O	TTa		SPI1_MOSI, TIM3_CH2, TIM14_CH1, TIM1_CH1N, TIM17_CH1, EVENTOUT	ADC_IN7
24	-	-	-	PC4	I/O	TTa		EVENTOUT	ADC_IN14
25	-	-	-	PC5	I/O	TTa		-	ADC_IN15
26	18	14	-	PB0	I/O	TTa		TIM3_CH3, TIM1_CH2N, EVENTOUT	ADC_IN8
27	19	15	14	PB1	I/O	TTa		TIM3_CH4, TIM14_CH1, TIM1_CH3N	ADC_IN9
28	20	-	-	PB2	I/O	FT	<sup>(4)</sup>	-	-
29	21	-	-	PB10	I/O	FT		I2C1_SCL <sup>(2)</sup> , I2C2_SCL <sup>(3)</sup>	-
30	22	-	-	PB11	I/O	FT		I2C1_SDA <sup>(2)</sup> , I2C2_SDA <sup>(3)</sup> , EVENTOUT	-
31	23	16	-	VSS	S			Ground	
32	24	17	16	VDD	S			Digital power supply	
33	25	-	-	PB12	I/O	FT		SPI1_NSS <sup>(2)</sup> , SPI2_NSS <sup>(3)</sup> , TIM1_BKIN, EVENTOUT	-

Table 11. Pin definitions (continued)

Pin number				Pin name (function after reset)	Pin type	I/O structure	Notes	Pin functions	
LQFP64	LQFP48	LQFP32	TSSOP20					Alternate functions	Additional functions
34	26	-	-	PB13	I/O	FT		SPI1_SCK <sup>(2)</sup> , SPI2_SCK <sup>(3)</sup> , TIM1_CH1N	-
35	27	-	-	PB14	I/O	FT		SPI1_MISO <sup>(2)</sup> , SPI2_MISO <sup>(3)</sup> , TIM1_CH2N, TIM15_CH1 <sup>(3)</sup>	-
36	28	-	-	PB15	I/O	FT		SPI1_MOSI <sup>(2)</sup> , SPI2_MOSI <sup>(3)</sup> , TIM1_CH3N, TIM15_CH1N <sup>(3)</sup> , TIM15_CH2 <sup>(3)</sup>	RTC_REFIN
37	-	-	-	PC6	I/O	FT		TIM3_CH1	-
38	-	-	-	PC7	I/O	FT		TIM3_CH2	-
39	-	-	-	PC8	I/O	FT		TIM3_CH3	-
40	-	-	-	PC9	I/O	FT		TIM3_CH4	-
41	29	18	-	PA8	I/O	FT		USART1_CK, TIM1_CH1, EVENTOUT, MCO	-
42	30	19	17	PA9	I/O	FT		USART1_TX, TIM1_CH2, TIM15_BKIN <sup>(3)</sup> , I2C1_SCL <sup>(2)</sup>	-
43	31	20	18	PA10	I/O	FT		USART1_RX, TIM1_CH3, TIM17_BKIN, I2C1_SDA <sup>(2)</sup>	-
44	32	21	-	PA11	I/O	FT		USART1_CTS, TIM1_CH4, EVENTOUT	-
45	33	22	-	PA12	I/O	FT		USART1_RTS, TIM1_ETR, EVENTOUT	-
46	34	23	19	PA13 (SWDIO)	I/O	FT	(5)	IR_OUT, SWDIO	-
47	35	-	-	PF6	I/O	FT		I2C1_SCL <sup>(2)</sup> , I2C2_SCL <sup>(3)</sup>	-

Table 11. Pin definitions (continued)

Pin number				Pin name (function after reset)	Pin type	I/O structure	Notes	Pin functions	
LQFP64	LQFP48	LQFP32	TSSOP20					Alternate functions	Additional functions
48	36	-	-	PF7	I/O	FT		I2C1_SDA <sup>(2)</sup> , I2C2_SDA <sup>(3)</sup>	-
49	37	24	20	PA14 (SWCLK)	I/O	FT	(5)	USART1_TX <sup>(2)</sup> , USART2_TX <sup>(3)</sup> , SWCLK	-
50	38	25	-	PA15	I/O	FT		SPI1_NSS, USART1_RX <sup>(2)</sup> , USART2_RX <sup>(3)</sup> , EVENTOUT	-
51	-	-	-	PC10	I/O	FT		-	-
52	-	-	-	PC11	I/O	FT		-	-
53	-	-	-	PC12	I/O	FT		-	-
54	-	-	-	PD2	I/O	FT		TIM3_ETR	-
55	39	26	-	PB3	I/O	FT		SPI1_SCK, EVENTOUT	-
56	40	27	-	PB4	I/O	FT		SPI1_MISO, TIM3_CH1, EVENTOUT	-
57	41	28	-	PB5	I/O	FT		SPI1_MOSI, I2C1_SMBA, TIM16_BKIN, TIM3_CH2	-
58	42	29	-	PB6	I/O	FTf		I2C1_SCL, USART1_TX, TIM16_CH1N	-
59	43	30	-	PB7	I/O	FTf		I2C1_SDA, USART1_RX, TIM17_CH1N	-
60	44	31	1	BOOT0	I	B		Boot memory selection	
61	45	-	-	PB8	I/O	FTf	(5)	I2C1_SCL, TIM16_CH1	-
62	46	-	-	PB9	I/O	FTf		I2C1_SDA, IR_OUT, TIM17_CH1, EVENTOUT	-

Table 11. Pin definitions (continued)

Pin number				Pin name (function after reset)	Pin type	I/O structure	Notes	Pin functions	
LQFP64	LQFP48	LQFP32	TSSOP20					Alternate functions	Additional functions
63	47	32	15	VSS	S			Ground	
64	48	1	16	VDD	S			Digital power supply	

- PC13, PC14 and PC15 are supplied through the power switch. Since the switch only sinks a limited amount of current (3 mA), the use of GPIOs PC13 to PC15 in output mode is limited:
  - The speed should not exceed 2 MHz with a maximum load of 30 pF.
  - These GPIOs must not be used as current sources (e.g. to drive an LED).
- This feature is available on STM32F030x6 and STM32F030x4 devices only.
- This feature is available on STM32F030x8 devices only.
- On LQFP32 package, PB2 and PB8 should be treated as unconnected pins (even when they are not available on the package, they are not forced to a defined level by hardware).
- After reset, these pins are configured as SWDIO and SWCLK alternate functions, and the internal pull-up on SWDIO pin and internal pull-down on SWCLK pin are activated.

**Table 12. Alternate functions selected through GPIOA\_AFR registers for port A**

Pin name	AF0	AF1	AF2	AF3	AF4	AF5	AF6
PA0	-	USART1_CTS <sup>(1)</sup>	-	-	-	-	-
		USART2_CTS <sup>(2)</sup>					
PA1	EVENTOUT	USART1_RTS <sup>(1)</sup>	-	-	-	-	-
		USART2_RTS <sup>(2)</sup>					
PA2	TIM15_CH1 <sup>(2)</sup>	USART1_TX <sup>(1)</sup>	-	-	-	-	-
		USART2_TX <sup>(2)</sup>					
PA3	TIM15_CH2 <sup>(2)</sup>	USART1_RX <sup>(1)</sup>	-	-	-	-	-
		USART2_RX <sup>(2)</sup>					
PA4	SPI1_NSS	USART1_CK <sup>(1)</sup>	-	-	TIM14_CH1	-	-
		USART2_CK <sup>(2)</sup>					
PA5	SPI1_SCK	-	-	-	-	-	-
PA6	SPI1_MISO	TIM3_CH1	TIM1_BKIN	-	-	TIM16_CH1	EVENTOUT
PA7	SPI1_MOSI	TIM3_CH2	TIM1_CH1N	-	TIM14_CH1	TIM17_CH1	EVENTOUT
PA8	MCO	USART1_CK	TIM1_CH1	EVENTOUT	-	-	-
PA9	TIM15_BKIN <sup>(2)</sup>	USART1_TX	TIM1_CH2	-	I2C1_SCL <sup>(1)</sup>	-	-
PA10	TIM17_BKIN	USART1_RX	TIM1_CH3	-	I2C1_SDA <sup>(1)</sup>	-	-
PA11	EVENTOUT	USART1_CTS	TIM1_CH4	-	-	-	-
PA12	EVENTOUT	USART1_RTS	TIM1_ETR	-	-	-	-
PA13	SWDIO	IR_OUT	-	-	-	-	-
PA14	SWCLK	USART1_TX <sup>(1)</sup>	-	-	-	-	-
		USART2_TX <sup>(2)</sup>					
PA15	SPI1_NSS	USART1_RX <sup>(1)</sup>	-	EVENTOUT	-	-	-
		USART2_RX <sup>(2)</sup>					

1. This feature is available on STM32F030x6 and STM32F030x4 devices only.

2. This feature is available on STM32F030x8 devices only.



Table 13. Alternate functions selected through GPIOB\_AFR registers for port B

Pin name	AF0	AF1	AF2	AF3
PB0	EVENTOUT	TIM3_CH3	TIM1_CH2N	-
PB1	TIM14_CH1	TIM3_CH4	TIM1_CH3N	-
PB2	-	-	-	-
PB3	SPI1_SCK	EVENTOUT	-	-
PB4	SPI1_MISO	TIM3_CH1	EVENTOUT	-
PB5	SPI1_MOSI	TIM3_CH2	TIM16_BKIN	I2C1_SMBA
PB6	USART1_TX	I2C1_SCL	TIM16_CH1N	-
PB7	USART1_RX	I2C1_SDA	TIM17_CH1N	-
PB8	-	I2C1_SCL	TIM16_CH1	-
PB9	IR_OUT	I2C1_SDA	TIM17_CH1	EVENTOUT
PB10	-	I2C1_SCL <sup>(1)</sup>	-	-
		I2C2_SCL <sup>(2)</sup>		
PB11	EVENTOUT	I2C1_SDA <sup>(1)</sup>	-	-
		I2C2_SDA <sup>(2)</sup>		
PB12	SPI1_NSS <sup>(1)</sup>	EVENTOUT	TIM1_BKIN	-
	SPI2_NSS <sup>(2)</sup>			
PB13	SPI1_SCK <sup>(1)</sup>	-	TIM1_CH1N	-
	SPI2_SCK <sup>(2)</sup>			
PB14	SPI1_MISO <sup>(1)</sup>	TIM15_CH1 <sup>(2)</sup>	TIM1_CH2N	-
	SPI2_MISO <sup>(2)</sup>			
PB15	SPI1_MOSI <sup>(1)</sup>	TIM15_CH2 <sup>(2)</sup>	TIM1_CH3N	TIM15_CH1N <sup>(2)</sup>
	SPI2_MOSI <sup>(2)</sup>			

1. This feature is available on STM32F030x6 and STM32F030x4 devices only.

2. This feature is available on STM32F030x8 devices only.



# 5 Memory mapping

Figure 7. STM32F030x memory map

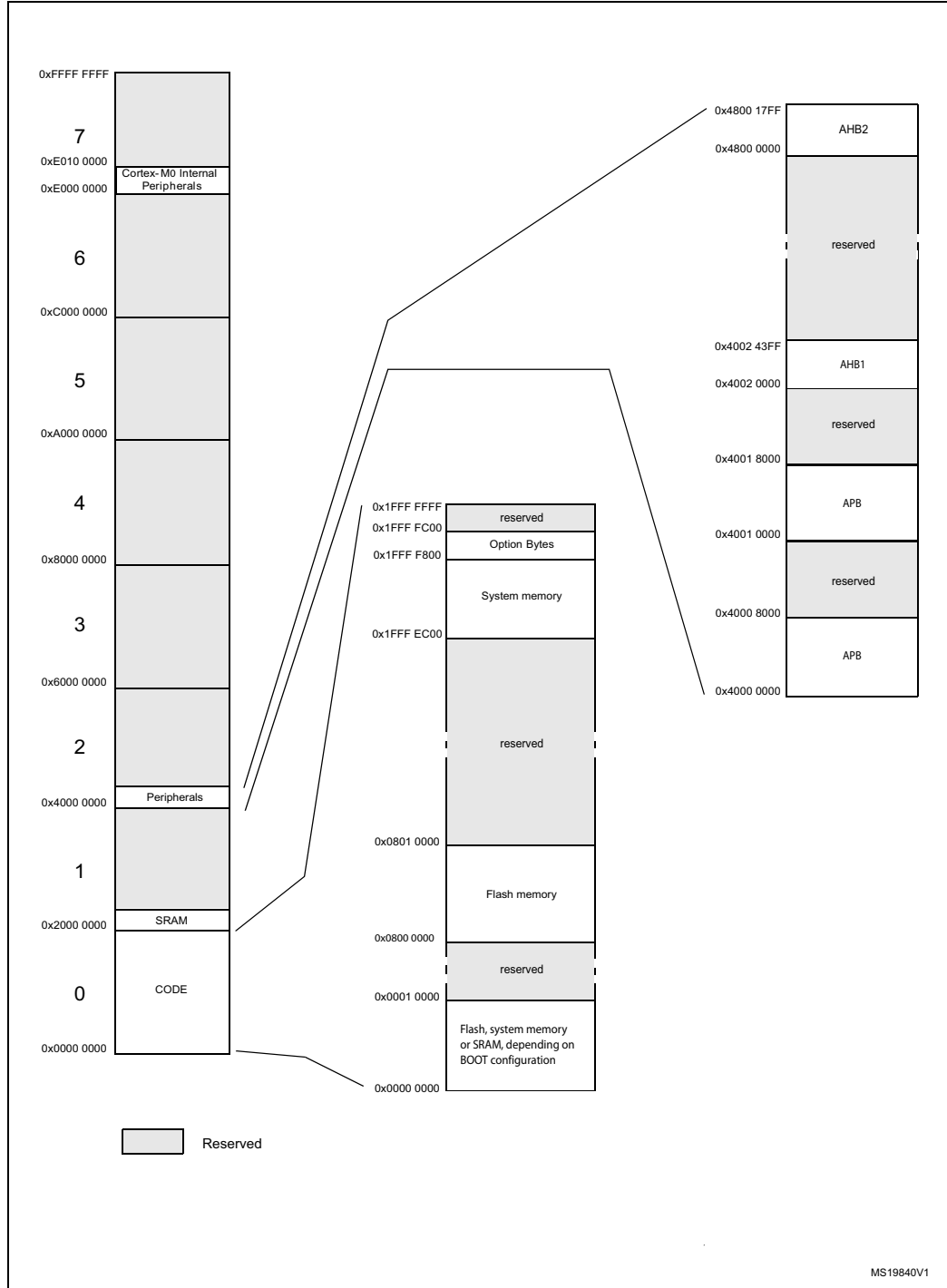


Table 14. STM32F030x peripheral register boundary addresses

Bus	Boundary address	Size	Peripheral
	0x4800 1800 - 0x5FFF FFFF	~384 MB	Reserved
AHB2	0x4800 1400 - 0x4800 17FF	1 KB	GPIOF
	0x4800 1000 - 0x4800 13FF	1 KB	Reserved
	0x4800 0C00 - 0x4800 0FFF	1 KB	GPIOD
	0x4800 0800 - 0x4800 0BFF	1 KB	GPIOC
	0x4800 0400 - 0x4800 07FF	1 KB	GPIOB
	0x4800 0000 - 0x4800 03FF	1 KB	GPIOA
	0x4002 4400 - 0x47FF FFFF	~128 MB	Reserved
AHB1	0x4002 3400 - 0x4002 43FF	4 KB	Reserved
	0x4002 3000 - 0x4002 33FF	1 KB	CRC
	0x4002 2400 - 0x4002 2FFF	3 KB	Reserved
	0x4002 2000 - 0x4002 23FF	1 KB	FLASH Interface
	0x4002 1400 - 0x4002 1FFF	3 KB	Reserved
	0x4002 1000 - 0x4002 13FF	1 KB	RCC
	0x4002 0400 - 0x4002 0FFF	3 KB	Reserved
	0x4002 0000 - 0x4002 03FF	1 KB	DMA
	0x4001 8000 - 0x4001 FFFF	32 KB	Reserved
APB	0x4001 5C00 - 0x4001 7FFF	9 KB	Reserved
	0x4001 5800 - 0x4001 5BFF	1 KB	DBGMCU
	0x4001 4C00 - 0x4001 57FF	3 KB	Reserved
	0x4001 4800 - 0x4001 4BFF	1 KB	TIM17
	0x4001 4400 - 0x4001 47FF	1 KB	TIM16
	0x4001 4000 - 0x4001 43FF	1 KB	TIM15 <sup>(1)</sup>
	0x4001 3C00 - 0x4001 3FFF	1 KB	Reserved
	0x4001 3800 - 0x4001 3BFF	1 KB	USART1
	0x4001 3400 - 0x4001 37FF	1 KB	Reserved
	0x4001 3000 - 0x4001 33FF	1 KB	SPI1
	0x4001 2C00 - 0x4001 2FFF	1 KB	TIM1
	0x4001 2800 - 0x4001 2BFF	1 KB	Reserved
	0x4001 2400 - 0x4001 27FF	1 KB	ADC
	0x4001 0800 - 0x4001 23FF	7 KB	Reserved
	0x4001 0400 - 0x4001 07FF	1 KB	EXTI
	0x4001 0000 - 0x4001 03FF	1 KB	SYSCFG
		0x4000 8000 - 0x4000 FFFF	32 KB

Table 14. STM32F030x peripheral register boundary addresses (continued)

Bus	Boundary address	Size	Peripheral
APB	0x4000 7400 - 0x4000 7FFF	3 KB	Reserved
	0x4000 7000 - 0x4000 73FF	1 KB	PWR
	0x4000 5C00 - 0x4000 6FFF	5 KB	Reserved
	0x4000 5800 - 0x4000 5BFF	1 KB	I2C2 <sup>(1)</sup>
	0x4000 5400 - 0x4000 57FF	1 KB	I2C1
	0x4000 4800 - 0x4000 53FF	3 KB	Reserved
	0x4000 4400 - 0x4000 47FF	1 KB	USART2 <sup>(1)</sup>
	0x4000 3C00 - 0x4000 43FF	2 KB	Reserved
	0x4000 3800 - 0x4000 3BFF	1 KB	SPI2 <sup>(1)</sup>
	0x4000 3400 - 0x4000 37FF	1 KB	Reserved
	0x4000 3000 - 0x4000 33FF	1 KB	IWDG
	0x4000 2C00 - 0x4000 2FFF	1 KB	WWDG
	0x4000 2800 - 0x4000 2BFF	1 KB	RTC
	0x4000 2400 - 0x4000 27FF	1 KB	Reserved
	0x4000 2000 - 0x4000 23FF	1 KB	TIM14
	0x4000 1400 - 0x4000 1FFF	3 KB	Reserved
	0x4000 1000 - 0x4000 13FF	1 KB	TIM6 <sup>(1)</sup>
	0x4000 0800 - 0x4000 0FFF	2 KB	Reserved
	0x4000 0400 - 0x4000 07FF	1 KB	TIM3
0x4000 0000 - 0x4000 03FF	1 KB	Reserved	

1. This feature is available on STM32F030x8 devices only. For STM32F030x6 and STM32F060x4, the area is Reserved.

## 6 Electrical characteristics

### 6.1 Parameter conditions

Unless otherwise specified, all voltages are referenced to  $V_{SS}$ .

#### 6.1.1 Minimum and maximum values

Unless otherwise specified, the minimum and maximum values are guaranteed in the worst conditions of ambient temperature, supply voltage and frequencies by tests in production on 100% of the devices with an ambient temperature at  $T_A = 25\text{ }^\circ\text{C}$  and  $T_A = T_{Amax}$  (given by the selected temperature range).

Data based on characterization results, design simulation and/or technology characteristics are indicated in the table footnotes and are not tested in production. Based on characterization, the minimum and maximum values refer to sample tests and represent the mean value plus or minus three times the standard deviation ( $\text{mean} \pm 3\sigma$ ).

#### 6.1.2 Typical values

Unless otherwise specified, typical data are based on  $T_A = 25\text{ }^\circ\text{C}$ ,  $V_{DD} = V_{DDA} = 3.3\text{ V}$ . They are given only as design guidelines and are not tested.

Typical ADC accuracy values are determined by characterization of a batch of samples from a standard diffusion lot over the full temperature range, where 95% of the devices have an error less than or equal to the value indicated ( $\text{mean} \pm 2\sigma$ ).

#### 6.1.3 Typical curves

Unless otherwise specified, all typical curves are given only as design guidelines and are not tested.

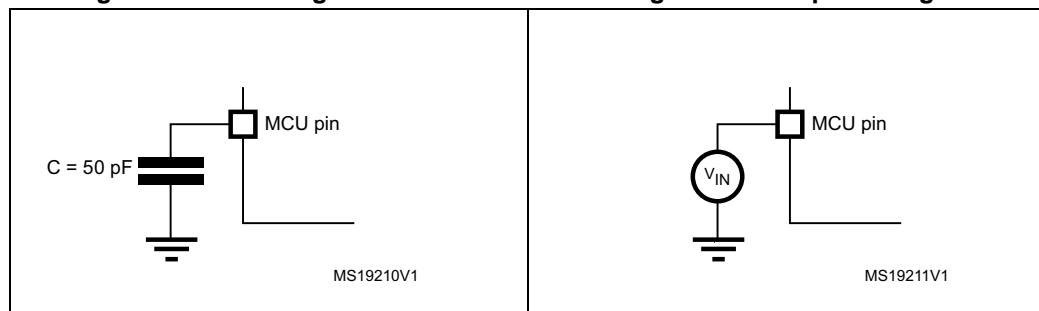
#### 6.1.4 Loading capacitor

The loading conditions used for pin parameter measurement are shown in [Figure 8](#).

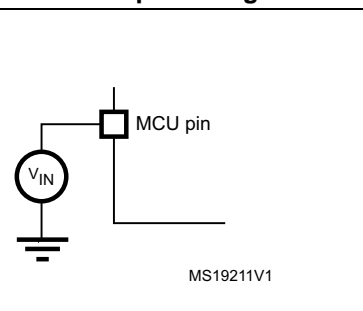
#### 6.1.5 Pin input voltage

The input voltage measurement on a pin of the device is described in [Figure 9](#).

**Figure 8. Pin loading conditions**

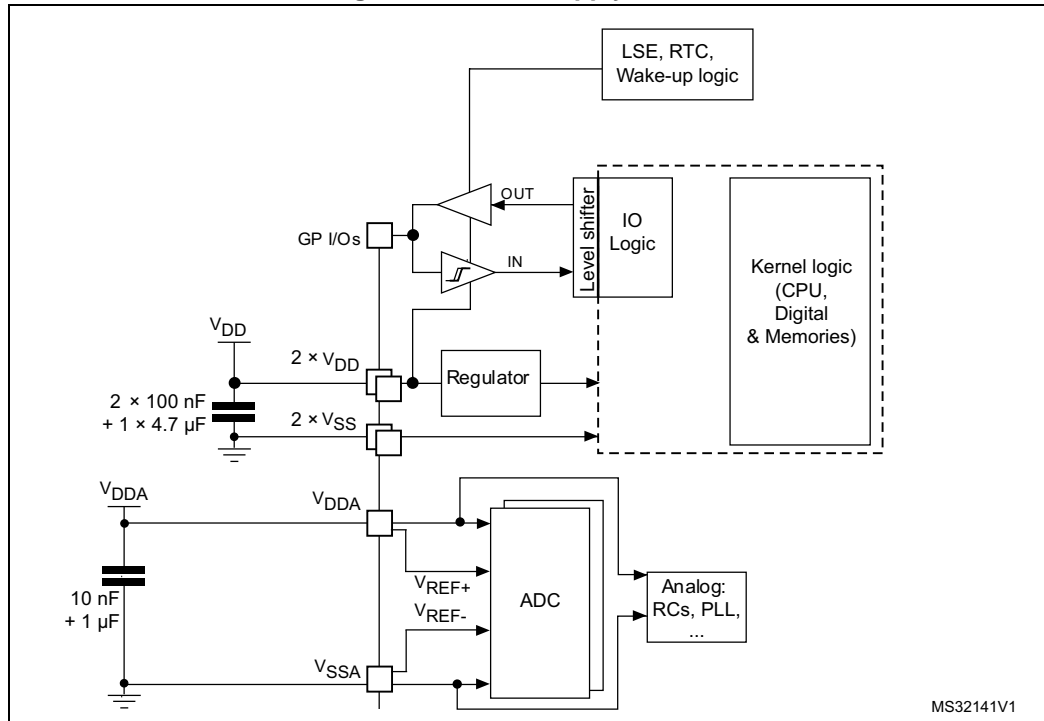


**Figure 9. Pin input voltage**



## 6.1.6 Power supply scheme

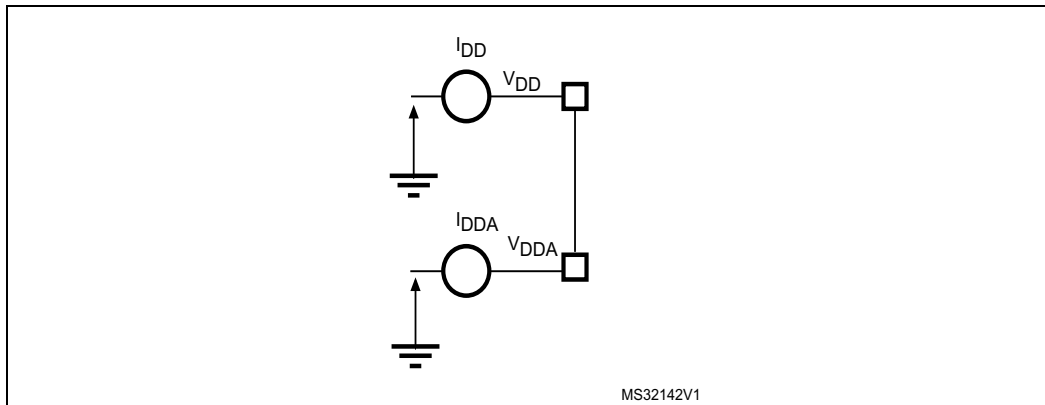
Figure 10. Power supply scheme



**Caution:** Each power supply pair ( $V_{DD}/V_{SS}$ ,  $V_{DDA}/V_{SSA}$  etc.) must be decoupled with filtering ceramic capacitors as shown above. These capacitors must be placed as close as possible to, or below, the appropriate pins on the underside of the PCB to ensure the good functionality of the device.

### 6.1.7 Current consumption measurement

Figure 11. Current consumption measurement scheme



## 6.2 Absolute maximum ratings

Stresses above the absolute maximum ratings listed in [Table 15: Voltage characteristics](#), [Table 16: Current characteristics](#), and [Table 17: Thermal characteristics](#) may cause permanent damage to the device. These are stress ratings only and functional operation of the device at these conditions is not implied. Exposure to maximum rating conditions for extended periods may affect device reliability.

Table 15. Voltage characteristics<sup>(1)</sup>

Symbol	Ratings	Min	Max	Unit
$V_{DD}-V_{SS}$	External main supply voltage (including $V_{DDA}$ and $V_{DD}$ )	-0.3	4.0	V
$V_{DD}-V_{DDA}$	Allowed voltage difference for $V_{DD} > V_{DDA}$	-	0.4	V
$V_{IN}^{(2)}$	Input voltage on FT and FTf pins	$V_{SS} - 0.3$	$V_{DD} + 4.0$	V
	Input voltage on TTa pins	$V_{SS} - 0.3$	4.0	V
	Input voltage on any other pin	$V_{SS} - 0.3$	4.0	V
$ \Delta V_{DDx} $	Variations between different $V_{DD}$ power pins	-	50	mV
$ V_{SSx} - V_{SS} $	Variations between all the different ground pins	-	50	mV
$V_{ESD(HBM)}$	Electrostatic discharge voltage (human body model)	see <a href="#">Section 6.3.12: Electrical sensitivity characteristics</a>		

- All main power ( $V_{DD}$ ,  $V_{DDA}$ ) and ground ( $V_{SS}$ ,  $V_{SSA}$ ) pins must always be connected to the external power supply, in the permitted range.
- $V_{IN}$  maximum must always be respected. Refer to [Table 16: Current characteristics](#) for the maximum allowed injected current values.

Table 16. Current characteristics

Symbol	Ratings	Max.	Unit
$\Sigma I_{VDD}$	Total current into sum of all VDD_x and VDDSDx power lines (source) <sup>(1)</sup>	120	mA
$\Sigma I_{VSS}$	Total current out of sum of all VSS_x and VSSSD ground lines (sink) <sup>(1)</sup>	-120	
$I_{VDD(PIN)}$	Maximum current into each VDD_x or VDDSDx power pin (source) <sup>(1)</sup>	100	
$I_{VSS(PIN)}$	Maximum current out of each VSS_x or VSSSD ground pin (sink) <sup>(1)</sup>	-100	
$I_{IO(PIN)}$	Output current sunk by any I/O and control pin	25	
	Output current source by any I/O and control pin	-25	
$\Sigma I_{IO(PIN)}$	Total output current sunk by sum of all IOs and control pins <sup>(2)</sup>	80	
	Total output current sourced by sum of all IOs and control pins <sup>(2)</sup>	-80	
$I_{INJ(PIN)}$	Injected current on FT, FTf and B pins <sup>(3)</sup>	-5/+0	
	Injected current on TC and RST pin <sup>(4)</sup>	± 5	
	Injected current on TTA pins <sup>(5)</sup>	± 5	
$\Sigma I_{INJ(PIN)}$	Total injected current (sum of all I/O and control pins) <sup>(6)</sup>	± 25	

- All main power (VDD, VDDA) and ground (VSS, VSSA) pins must always be connected to the external power supply, in the permitted range.
- This current consumption must be correctly distributed over all I/Os and control pins. The total output current must not be sunk/sourced between two consecutive power supply pins referring to high pin count QFP packages.
- Positive injection is not possible on these I/Os and does not occur for input voltages lower than the specified maximum value.
- A positive injection is induced by  $V_{IN} > V_{DD}$  while a negative injection is induced by  $V_{IN} < V_{SS}$ .  $I_{INJ(PIN)}$  must never be exceeded. Refer to [Table 15: Voltage characteristics](#) for the maximum allowed input voltage values.
- A positive injection is induced by  $V_{IN} > V_{DDA}$  while a negative injection is induced by  $V_{IN} < V_{SS}$ .  $I_{INJ(PIN)}$  must never be exceeded. Refer also to [Table 15: Voltage characteristics](#) for the maximum allowed input voltage values. Negative injection disturbs the analog performance of the device. See note <sup>(2)</sup> below [Table 50: ADC accuracy](#).
- When several inputs are submitted to a current injection, the maximum  $\Sigma I_{INJ(PIN)}$  is the absolute sum of the positive and negative injected currents (instantaneous values).

Table 17. Thermal characteristics

Symbol	Ratings	Value	Unit
$T_{STG}$	Storage temperature range	-65 to +150	°C
$T_J$	Maximum junction temperature	150	°C

## 6.3 Operating conditions

### 6.3.1 General operating conditions

Table 18. General operating conditions

Symbol	Parameter	Conditions	Min	Max	Unit
$f_{\text{HCLK}}$	Internal AHB clock frequency		0	48	MHz
$f_{\text{PCLK}}$	Internal APB clock frequency		0	48	
$V_{\text{DD}}$	Standard operating voltage		2.4	3.6	V
$V_{\text{DDA}}$	Analog operating voltage	Must have a potential equal to or higher than $V_{\text{DD}}$	2.4	3.6	V
$V_{\text{IN}}^{(1)}$	Input voltage on FT and FTf pins		$V_{\text{SS}} - 0.3$	$V_{\text{DD}} + 4.0$	V
	Input voltage on TTa pins		$V_{\text{SS}} - 0.3$	4.0	V
	Input voltage on any other pin		$V_{\text{SS}} - 0.3$	4.0	V
$P_{\text{D}}$	Power dissipation at $T_{\text{A}} = 85\text{ }^{\circ}\text{C}$ for suffix 6 <sup>(2)</sup>	LQFP64	-	444	mW
		LQFP48	-	364	
		LQFP32	-	357	
		TSSOP20	-	182	
$T_{\text{A}}$	Ambient temperature for 6 suffix version	Maximum power dissipation	-40	85	$^{\circ}\text{C}$
		Low power dissipation <sup>(3)</sup>	-40	105	
$T_{\text{J}}$	Junction temperature range	6 suffix version	-40	105	$^{\circ}\text{C}$

- $V_{\text{IN}}$  maximum must always be respected. Refer to [Table 16: Current characteristics](#) for the maximum allowed injected current values.
- If  $T_{\text{A}}$  is lower, higher  $P_{\text{D}}$  values are allowed as long as  $T_{\text{J}}$  does not exceed  $T_{\text{Jmax}}$ .
- In low power dissipation state,  $T_{\text{A}}$  can be extended to this range as long as  $T_{\text{J}}$  does not exceed  $T_{\text{Jmax}}$ .



### 6.3.2 Operating conditions at power-up / power-down

The parameters given in [Table 19](#) are derived from tests performed under the ambient temperature condition summarized in [Table 18](#).

**Table 19. Operating conditions at power-up / power-down**

Symbol	Parameter	Conditions	Min	Max	Unit
$t_{VDD}$	$V_{DD}$ rise time rate		0	$\infty$	$\mu\text{s/V}$
	$V_{DD}$ fall time rate		20	$\infty$	
$t_{VDDA}$	$V_{DDA}$ rise time rate		0	$\infty$	
	$V_{DDA}$ fall time rate		20	$\infty$	

### 6.3.3 Embedded reset and power control block characteristics

The parameters given in [Table 20](#) are derived from tests performed under ambient temperature and  $V_{DD}$  supply voltage conditions summarized in [Table 18: General operating conditions](#).

**Table 20. Embedded reset and power control block characteristics**

Symbol	Parameter	Conditions	Min	Typ	Max	Unit
$V_{POR/PDR}^{(1)}$	Power on/power down reset threshold	Falling edge	1.8 <sup>(2)</sup>	1.88	2.06	V
		Rising edge	1.84	1.92	2.10	V
$V_{PDRhyst}^{(1)}$	PDR hysteresis		-	40	-	mV
$t_{RSTTEMPO}^{(3)}$	Reset temporization		1.5	2.5	4.5	ms

1. The PDR detector monitors  $V_{DD}$  and also  $V_{DDA}$  (if kept enabled in the option bytes). The POR detector monitors only  $V_{DD}$ .
2. The product behavior is guaranteed by design down to the minimum  $V_{POR/PDR}$  value.
3. Guaranteed by design, not tested in production.

### 6.3.4 Embedded reference voltage

The parameters given in [Table 21](#) are derived from tests performed under ambient temperature and  $V_{DD}$  supply voltage conditions summarized in [Table 18: General operating conditions](#).

**Table 21. Embedded internal reference voltage**

Symbol	Parameter	Conditions	Min	Typ	Max	Unit
$V_{REFINT}$	Internal reference voltage	$-40\text{ }^{\circ}\text{C} < T_A < +85\text{ }^{\circ}\text{C}$	1.16	1.2	1.24 <sup>(1)</sup>	V
$T_{S\_vrefint}^{(2)}$	ADC sampling time when reading the internal reference voltage		-	5.1	17.1 <sup>(3)</sup>	$\mu\text{s}$

Table 21. Embedded internal reference voltage (continued)

Symbol	Parameter	Conditions	Min	Typ	Max	Unit
$\Delta V_{REFINT}$	Internal reference voltage spread over the temperature range	$V_{DDA} = 3 \text{ V} \pm 10 \text{ mV}$	-	-	10 <sup>(3)</sup>	mV
$T_{Coeff}$	Temperature coefficient		-	-	100 <sup>(3)</sup>	ppm/°C

1. Data based on characterization results, not tested in production.
2. Shortest sampling time can be determined in the application by multiple iterations.
3. Guaranteed by design, not tested in production.

### 6.3.5 Supply current characteristics

The current consumption is a function of several parameters and factors such as the operating voltage, ambient temperature, I/O pin loading, device software configuration, operating frequencies, I/O pin switching rate, program location in memory and executed binary code.

The current consumption is measured as described in [Figure 11: Current consumption measurement scheme](#).

All Run-mode current consumption measurements given in this section are performed with a reduced code that gives a consumption equivalent to CoreMark code.

#### Typical and maximum current consumption

The MCU is placed under the following conditions:

- All I/O pins are in input mode with a static value at  $V_{DD}$  or  $V_{SS}$  (no load)
- All peripherals are disabled except when explicitly mentioned
- The Flash memory access time is adjusted to the  $f_{HCLK}$  frequency (0 wait state from 0 to 24 MHz and 1 wait state above 24 MHz)
- Prefetch is ON when the peripherals are enabled, otherwise it is OFF (to enable prefetch the PRFTBE bit in the FLASH\_ACR register must be set before clock setting and bus prescaling)
- When the peripherals are enabled  $f_{PCLK} = f_{HCLK}$

The parameters given in [Table 22](#) to are derived from tests performed under ambient temperature and supply voltage conditions summarized in [Table 18: General operating conditions](#).

**Table 22. Typical and maximum current consumption from V<sub>DD</sub> supply at V<sub>DD</sub> = 3.6**

Symbol	Parameter	Conditions	f <sub>HCLK</sub>	All peripherals enabled		Unit
				Typ	Max @ T <sub>A</sub> <sup>(1)</sup>	
					85 °C	
I <sub>DD</sub>	Supply current in Run mode, code executing from Flash	HSI clock, PLL on	48 MHz	22	22.8	mA
			24 MHz	12.2	13.2	
		HSI clock, PLL off	8 MHz	4.4	5.2	
	Supply current in Run mode, code executing from RAM	HSI clock, PLL on	48 MHz	22.2	23.2	
			24 MHz	11.2	12.2	
		HSI clock, PLL off	8 MHz	4.0	4.5	
	Supply current in Sleep mode, code executing from Flash or RAM	HSI clock, PLL on	48 MHz	14	15.3	
			24 MHz	7.3	7.8	
		HSI clock, PLL off	8 MHz	2.6	2.9	

1. Data based on characterization results, not tested in production unless otherwise specified.

**Table 23. Typical and maximum current consumption from the V<sub>DDA</sub> supply**

Symbol	Parameter	Conditions <sup>(1)</sup>	f <sub>HCLK</sub>	V <sub>DDA</sub> = 3.6 V		Unit
				Typ	Max @ T <sub>A</sub> <sup>(2)</sup>	
					85 °C	
I <sub>DDA</sub>	Supply current in Run mode, code executing from Flash or RAM	HSE bypass, PLL on	48 MHz	175	215	μA
		HSE bypass, PLL off	8 MHz	3.9	4.9	
			1 MHz	3.9	4.1	
		HSI clock, PLL on	48 MHz	244	275	
	8 MHz		85	105		
	Supply current in Sleep mode, code executing from Flash or RAM	HSE bypass, PLL on	48 MHz	174	215	
		HSE bypass, PLL off	8 MHz	3.9	4.9	
			1 MHz	3.9	4.9	
		HSI clock, PLL on	48 MHz	244	299	
			8 MHz	85	105	

1. Current consumption from the V<sub>DDA</sub> supply is independent of whether the peripherals are on or off. Furthermore when the PLL is off, I<sub>DDA</sub> is independent from the frequency.

2. Data based on characterization results, not tested in production.

Table 24. Typical and maximum  $V_{DD}$  consumption in Stop and Standby modes

Symbol	Parameter	Conditions	Typ @ $V_{DD}$ ( $V_{DD} = V_{DDA}$ )	Max <sup>(1)</sup>	Unit
			3.6 V	$T_A = 85\text{ }^\circ\text{C}$	
$I_{DD}$	Supply current in Stop mode	Regulator in run mode, all oscillators OFF	19	48	$\mu\text{A}$
		Regulator in low-power mode, all oscillators OFF	5	32	
	Supply current in Standby mode	LSI ON and IWDG ON	2	-	

1. Data based on characterization results, not tested in production unless otherwise specified.

Table 25. Typical and maximum  $V_{DDA}$  consumption in Stop and Standby modes

Symbol	Parameter	Conditions	Typ @ $V_{DD}$ ( $V_{DD} = V_{DDA}$ )	Max <sup>(1)</sup>	Unit	
			3.6 V	$T_A = 85\text{ }^\circ\text{C}$		
$I_{DDA}$	Supply current in Stop mode	$V_{DDA}$ monitoring ON	Regulator in run or low power mode, all oscillators OFF	2.9	3.5	$\mu\text{A}$
			LSI ON and IWDG ON	3.3	-	
			LSI OFF and IWDG OFF	2.8	3.5	
	Supply current in Standby mode	$V_{DDA}$ monitoring OFF	Regulator in run mode or low power, all oscillators OFF	1.7	-	
			LSI ON and IWDG ON	2.3	-	
			LSI OFF and IWDG OFF	1.4	-	

1. Data based on characterization results, not tested in production.

### Typical current consumption

The MCU is placed under the following conditions:

- $V_{DD}=V_{DDA}=3.3$  V
- All I/O pins are in analog input configuration
- The Flash access time is adjusted to  $f_{HCLK}$  frequency (0 wait states from 0 to 24 MHz, 1 wait state above)
- Prefetch is ON when the peripherals are enabled, otherwise it is OFF
- When the peripherals are enabled,  $f_{PCLK} = f_{HCLK}$
- PLL is used for frequencies greater than 8 MHz
- AHB prescaler of 2, 4, 8 and 16 is used for the frequencies 4 MHz, 2 MHz, 1 MHz and 500 kHz respectively
- A development tool is connected to the board and the parasitic pull-up current is around 30  $\mu$ A

**Table 26. Typical current consumption in Run mode, code with data processing running from Flash**

Symbol	Parameter	Conditions	$f_{HCLK}$	Typ		Unit
				Peripherals enabled	Peripherals disabled	
$I_{DD}$	Supply current in Run mode from $V_{DD}$ supply	Running from HSE crystal clock 8 MHz, code executing from Flash	48 MHz	23.3	11.5	mA
			8 MHz	4.5	3.0	
$I_{DDA}$	Supply current in Run mode from $V_{DDA}$ supply		48 MHz	158	158	$\mu$ A
			8 MHz	2.43	2.43	

### I/O system current consumption

The current consumption of the I/O system has two components: static and dynamic.

#### I/O static current consumption

All the I/Os used as inputs with pull-up generate current consumption when the pin is externally held low. The value of this current consumption can be simply computed by using the pull-up/pull-down resistors values given in [Table 44: I/O static characteristics](#).

For the output pins, any external pull-down or external load must also be considered to estimate the current consumption.

Additional I/O current consumption is due to I/Os configured as inputs if an intermediate voltage level is externally applied. This current consumption is caused by the input Schmitt trigger circuits used to discriminate the input value. Unless this specific configuration is required by the application, this supply current consumption can be avoided by configuring these I/Os in analog mode. This is notably the case of ADC input pins which should be configured as analog inputs.

**Caution:** Any floating input pin can also settle to an intermediate voltage level or switch inadvertently, as a result of external electromagnetic noise. To avoid current consumption related to floating pins, they must either be configured in analog mode, or forced internally to a definite digital value. This can be done either by using pull-up/down resistors or by configuring the pins in output mode.

#### I/O dynamic current consumption

In addition to the internal peripheral current consumption measured previously (see [Table 26: Typical current consumption in Run mode, code with data processing running from Flash](#)), the I/Os used by an application also contribute to the current consumption. When an I/O pin switches, it uses the current from the MCU supply voltage to supply the I/O pin circuitry and to charge/discharge the capacitive load (internal or external) connected to the pin:

$$I_{SW} = V_{DD} \times f_{SW} \times C$$

where

$I_{SW}$  is the current sunk by a switching I/O to charge/discharge the capacitive load

$V_{DD}$  is the MCU supply voltage

$f_{SW}$  is the I/O switching frequency

$C$  is the total capacitance seen by the I/O pin:  $C = C_{INT} + C_{EXT} + C_S$

$C_S$  is the PCB board capacitance including the pad pin.

The test pin is configured in push-pull output mode and is toggled by software at a fixed frequency.

Table 27. Switching output I/O current consumption

Symbol	Parameter	Conditions <sup>(1)</sup>	I/O toggling frequency (f <sub>sw</sub> )	Typ	Unit
I <sub>sw</sub>	I/O current consumption	V <sub>DD</sub> = 3.3 V C <sub>EXT</sub> = 0 pF C = C <sub>INT</sub> + C <sub>EXT</sub> + C <sub>S</sub>	4 MHz	0.18	mA
			8 MHz	0.37	
			16 MHz	0.76	
			24 MHz	1.39	
			48 MHz	2.188	
		V <sub>DD</sub> = 3.3 V C <sub>EXT</sub> = 22 pF C = C <sub>INT</sub> + C <sub>EXT</sub> + C <sub>S</sub>	4 MHz	0.49	
			8 MHz	0.94	
			16 MHz	2.38	
			24 MHz	3.99	
		V <sub>DD</sub> = 3.3 V C <sub>EXT</sub> = 47 pF C = C <sub>INT</sub> + C <sub>EXT</sub> + C <sub>S</sub> C = C <sub>int</sub>	4 MHz	0.81	
			8 MHz	1.7	
			16 MHz	3.67	

1. C<sub>S</sub> = 7 pF (estimated value)

### 6.3.6 Wakeup time from low-power mode

The wakeup times given in [Table 28](#) is measured on a wakeup phase with a 8-MHz HSI RC oscillator. The event used to wake up the device depends from the current operating mode:

- Stop or sleep mode: the wakeup event is WFE.
- The wakeup pin used in stop and sleep mode is PA0 and in standby mode is PA1.

All timings are derived from tests performed under ambient temperature and V<sub>DD</sub> supply voltage conditions summarized in [Table 18: General operating conditions](#).

Table 28. Low-power mode wakeup timings

Symbol	Parameter	Conditions	Typ @V <sub>DD</sub> = 3.3 V	Max	Unit
t <sub>WUSTOP</sub>	Wakeup from Stop mode	Regulator in run mode	4.2	5	μs
t <sub>WUSTANDBY</sub>	Wakeup from Standby mode		50.96	-	
t <sub>WUSLEEP</sub>	Wakeup from Sleep mode		1.1	-	

### 6.3.7 External clock source characteristics

#### High-speed external user clock generated from an external source

In bypass mode the HSE oscillator is switched off and the input pin is a standard GPIO.

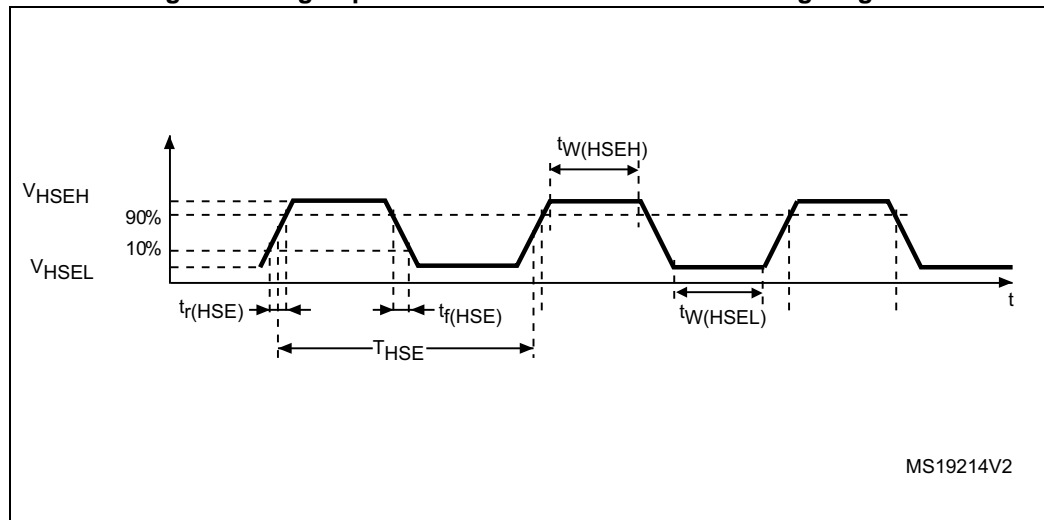
The external clock signal has to respect the I/O characteristics in [Section 6.3.14](#). However, the recommended clock input waveform is shown in [Figure 12: High-speed external clock source AC timing diagram](#).

**Table 29. High-speed external user clock characteristics**

Symbol	Parameter <sup>(1)</sup>	Conditions	Min	Typ	Max	Unit
$f_{\text{HSE\_ext}}$	User external clock source frequency		1	8	32	MHz
$V_{\text{HSEH}}$	OSC_IN input pin high level voltage		$0.7V_{\text{DD}}$	-	$V_{\text{DD}}$	V
$V_{\text{HSEL}}$	OSC_IN input pin low level voltage		$V_{\text{SS}}$	-	$0.3V_{\text{DD}}$	
$t_{\text{w}}(\text{HSEH})$ $t_{\text{w}}(\text{HSEL})$	OSC_IN high or low time		15	-	-	ns
$t_{\text{r}}(\text{HSE})$ $t_{\text{f}}(\text{HSE})$	OSC_IN rise or fall time		-	-	20	

1. Guaranteed by design, not tested in production.

**Figure 12. High-speed external clock source AC timing diagram**





### Low-speed external user clock generated from an external source

In bypass mode the LSE oscillator is switched off and the input pin is a standard GPIO.

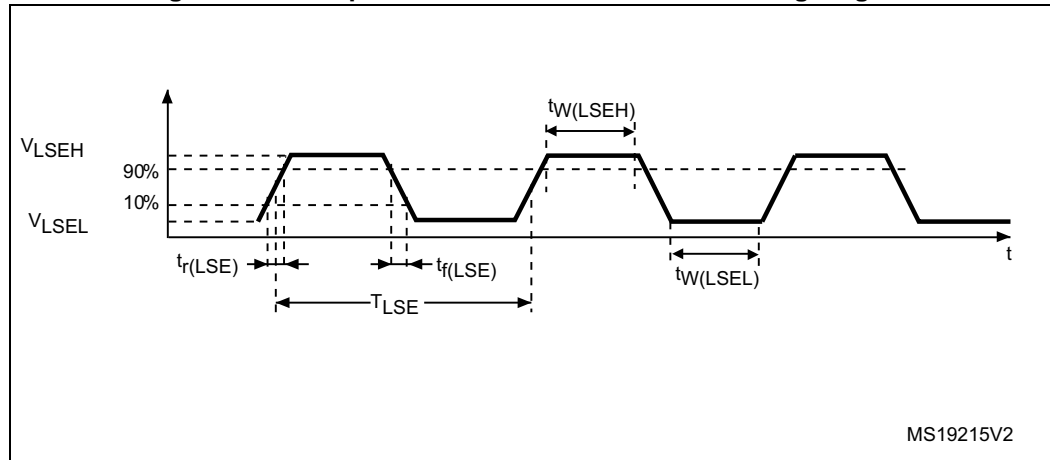
The external clock signal has to respect the I/O characteristics in [Section 6.3.14](#). However, the recommended clock input waveform is shown in [Figure 13](#).

**Table 30. Low-speed external user clock characteristics**

Symbol	Parameter <sup>(1)</sup>	Conditions	Min	Typ	Max	Unit
$f_{LSE\_ext}$	User External clock source frequency		-	32.768	1000	kHz
$V_{LSEH}$	OSC32_IN input pin high level voltage		$0.7V_{DD}$	-	$V_{DD}$	V
$V_{LSEL}$	OSC32_IN input pin low level voltage		$V_{SS}$	-	$0.3V_{DD}$	
$t_{w(LSEH)}$ $t_{w(LSEL)}$	OSC32_IN high or low time		450	-	-	ns
$t_{r(LSE)}$ $t_{f(LSE)}$	OSC32_IN rise or fall time		-	-	50	

1. Guaranteed by design, not tested in production.

**Figure 13. Low-speed external clock source AC timing diagram**



### High-speed external clock generated from a crystal/ceramic resonator

The high-speed external (HSE) clock can be supplied with a 4 to 32 MHz crystal/ceramic resonator oscillator. All the information given in this paragraph are based on design simulation results obtained with typical external components specified in [Table 31](#). In the application, the resonator and the load capacitors have to be placed as close as possible to the oscillator pins in order to minimize output distortion and startup stabilization time. Refer to the crystal resonator manufacturer for more details on the resonator characteristics (frequency, package, accuracy).

**Table 31. HSE oscillator characteristics**

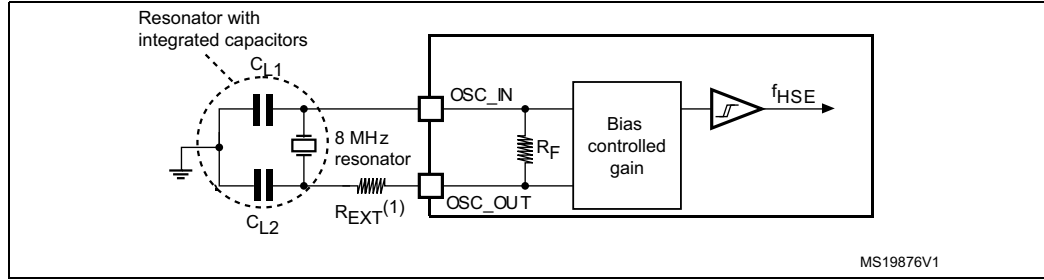
Symbol	Parameter	Conditions <sup>(1)</sup>	Min <sup>(2)</sup>	Typ	Max <sup>(2)</sup>	Unit
$f_{OSC\_IN}$	Oscillator frequency		4	8	32	MHz
$R_F$	Feedback resistor		-	200	-	k $\Omega$
$I_{DD}$	HSE current consumption	During startup <sup>(3)</sup>	-		8.5	mA
		$V_{DD}=3.3$ V, $R_m=45\Omega$ , $CL=10$ pF@8 MHz	-	0.5	-	
		$V_{DD}=3.3$ V, $R_m=30\Omega$ , $CL=20$ pF@32 MHz	-	1.5	-	
$g_m$	Oscillator transconductance	Startup	10	-	-	mA/V
$t_{SU(HSE)}$ <sup>(4)</sup>	Startup time	$V_{DD}$ is stabilized	-	2	-	ms

1. Resonator characteristics given by the crystal/ceramic resonator manufacturer.
2. Guaranteed by design, not tested in production.
3. This consumption level occurs during the first 2/3 of the  $t_{SU(HSE)}$  startup time
4.  $t_{SU(HSE)}$  is the startup time measured from the moment it is enabled (by software) to a stabilized 8 MHz oscillation is reached. This value is measured for a standard crystal resonator and it can vary significantly with the crystal manufacturer

For  $C_{L1}$  and  $C_{L2}$ , it is recommended to use high-quality external ceramic capacitors in the 5 pF to 20 pF range (typ.), designed for high-frequency applications, and selected to match the requirements of the crystal or resonator (see [Figure 14](#)).  $C_{L1}$  and  $C_{L2}$  are usually the same size. The crystal manufacturer typically specifies a load capacitance which is the series combination of  $C_{L1}$  and  $C_{L2}$ . PCB and MCU pin capacitance must be included (10 pF can be used as a rough estimate of the combined pin and board capacitance) when sizing  $C_{L1}$  and  $C_{L2}$ .

*Note:* For information on selecting the crystal, refer to the application note AN2867 "Oscillator design guide for ST microcontrollers" available from the ST website [www.st.com](http://www.st.com).

Figure 14. Typical application with an 8 MHz crystal



1.  $R_{EXT}$  value depends on the crystal characteristics.

**Low-speed external clock generated from a crystal resonator**

The low-speed external (LSE) clock can be supplied with a 32.768 kHz crystal resonator oscillator. All the information given in this paragraph are based on design simulation results obtained with typical external components specified in [Table 32](#). In the application, the resonator and the load capacitors have to be placed as close as possible to the oscillator pins in order to minimize output distortion and startup stabilization time. Refer to the crystal resonator manufacturer for more details on the resonator characteristics (frequency, package, accuracy).

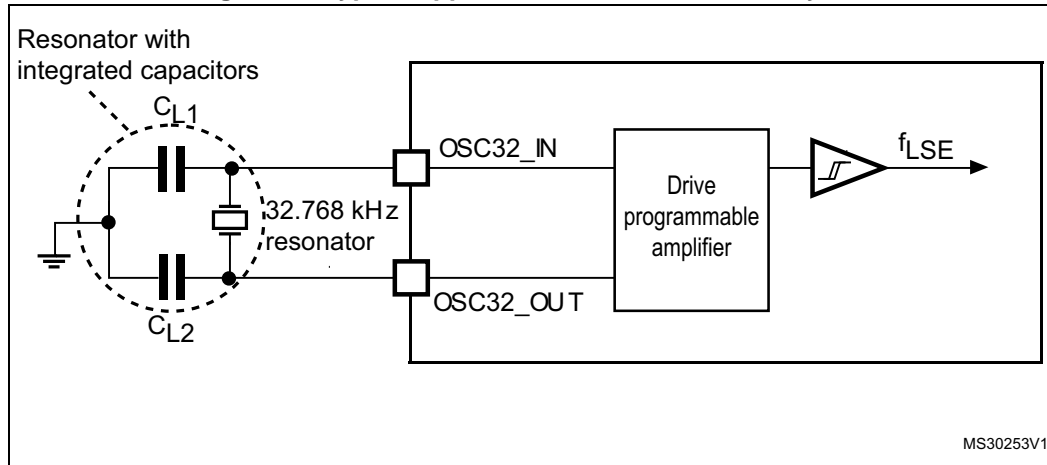
Table 32. LSE oscillator characteristics ( $f_{LSE} = 32.768$  kHz)

Symbol	Parameter	Conditions <sup>(1)</sup>	Min <sup>(2)</sup>	Typ	Max <sup>(2)</sup>	Unit
$I_{DD}$	LSE current consumption	LSEDRV[1:0]=00 lower driving capability	-	0.5	-	$\mu A$
		LSEDRV[1:0]= 01 medium low driving capability	-	0.8	-	
		LSEDRV[1:0] = 10 medium high driving capability	-	1.1	-	
		LSEDRV[1:0]=11 higher driving capability	-	1.4	-	
$g_m$	Oscillator transconductance	LSEDRV[1:0]=00 lower driving capability	5	-	-	$\mu A/V$
		LSEDRV[1:0]= 01 medium low driving capability	8	-	-	
		LSEDRV[1:0] = 10 medium high driving capability	15	-	-	
		LSEDRV[1:0]=11 higher driving capability	25	-	-	
$t_{SU(LSE)}^{(3)}$	Startup time	$V_{DD}$ is stabilized	-	2	-	s

1. Refer to the note and caution paragraphs below the table, and to the application note AN2867 "Oscillator design guide for ST microcontrollers".
2. Guaranteed by design, not tested in production.
3.  $t_{SU(LSE)}$  is the startup time measured from the moment it is enabled (by software) to a stabilized 32.768 kHz oscillation is reached. This value is measured for a standard crystal and it can vary significantly with the crystal manufacturer

Note: For information on selecting the crystal, refer to the application note AN2867 "Oscillator design guide for ST microcontrollers" available from the ST website [www.st.com](http://www.st.com).

Figure 15. Typical application with a 32.768 kHz crystal



Note: An external resistor is not required between OSC32\_IN and OSC32\_OUT and it is forbidden to add one.

### 6.3.8 Internal clock source characteristics

The parameters given in [Table 33](#) are derived from tests performed under ambient temperature and supply voltage conditions summarized in [Table 18: General operating conditions](#). The provided curves are characterization results, not tested in production.

#### High-speed internal (HSI) RC oscillator

Table 33. HSI oscillator characteristics<sup>(1)</sup>

Symbol	Parameter	Conditions	Min	Typ	Max	Unit
$f_{\text{HSI}}$	Frequency		-	8		MHz
TRIM	HSI user trimming step		-	-	1 <sup>(2)</sup>	%
DuCy <sub>(HSI)</sub>	Duty cycle		45 <sup>(2)</sup>	-	55 <sup>(2)</sup>	%
ACC <sub>HSI</sub>	Accuracy of the HSI oscillator (factory calibrated) <sup>(3)</sup>	$T_A = -40$ to $85$ °C	-	±5	-	%
		$T_A = 25$ °C	-	±1	-	%
$t_{\text{su(HSI)}}$	HSI oscillator startup time		1 <sup>(2)</sup>	-	2 <sup>(2)</sup>	µs
$I_{\text{DDA(HSI)}}$	HSI oscillator power consumption		-	80	-	µA

- $V_{\text{DDA}} = 3.3$  V,  $T_A = -40$  to  $85$  °C unless otherwise specified.
- Guaranteed by design, not tested in production.
- With user calibration.

**High-speed internal 14 MHz (HSI14) RC oscillator (dedicated to ADC)****Table 34. HSI14 oscillator characteristics<sup>(1)</sup>**

Symbol	Parameter	Conditions	Min	Typ	Max	Unit
$f_{\text{HSI14}}$	Frequency		-	14		MHz
TRIM	HSI14 user-trimming step		-	-	1 <sup>(2)</sup>	%
$\text{DuCy}_{(\text{HSI14})}$	Duty cycle		45 <sup>(2)</sup>	-	55 <sup>(2)</sup>	%
$\text{ACC}_{\text{HSI14}}$	Accuracy of the HSI14 oscillator (factory calibrated)	$T_A = -40 \text{ to } 85 \text{ }^\circ\text{C}$	-	$\pm 5$	-	%
$t_{\text{su}(\text{HSI14})}$	HSI14 oscillator startup time		1 <sup>(2)</sup>	-	2 <sup>(2)</sup>	$\mu\text{s}$
$I_{\text{DDA}(\text{HSI14})}$	HSI14 oscillator power consumption		-	100	-	$\mu\text{A}$

1.  $V_{\text{DDA}} = 3.3 \text{ V}$ ,  $T_A = -40 \text{ to } 85 \text{ }^\circ\text{C}$  unless otherwise specified.
2. Guaranteed by design, not tested in production.

**Low-speed internal (LSI) RC oscillator****Table 35. LSI oscillator characteristics<sup>(1)</sup>**

Symbol	Parameter	Min	Typ	Max	Unit
$f_{\text{LSI}}$	Frequency	30	40	50	kHz
$t_{\text{su}(\text{LSI})}^{(2)}$	LSI oscillator startup time	-	-	85	$\mu\text{s}$
$I_{\text{DDA}(\text{LSI})}^{(2)}$	LSI oscillator power consumption	-	0.75	-	$\mu\text{A}$

1.  $V_{\text{DDA}} = 3.3 \text{ V}$ ,  $T_A = -40 \text{ to } 85 \text{ }^\circ\text{C}$  unless otherwise specified.
2. Guaranteed by design, not tested in production.

**6.3.9 PLL characteristics**

The parameters given in [Table 36](#) are derived from tests performed under ambient temperature and supply voltage conditions summarized in [Table 18: General operating conditions](#).

Table 36. PLL characteristics

Symbol	Parameter	Value			Unit
		Min	Typ	Max	
f <sub>PLL_IN</sub>	PLL input clock <sup>(1)</sup>	1 <sup>(2)</sup>	-	24 <sup>(2)</sup>	MHz
	PLL input clock duty cycle	40 <sup>(2)</sup>	-	60 <sup>(2)</sup>	%
f <sub>PLL_OUT</sub>	PLL multiplier output clock	16 <sup>(2)</sup>	-	48	MHz
t <sub>LOCK</sub>	PLL lock time	-	-	200 <sup>(2)</sup>	μs
Jitter <sub>PLL</sub>	Cycle-to-cycle jitter	-	-	300 <sup>(2)</sup>	ps

1. Take care to use the appropriate multiplier factors to obtain PLL input clock values compatible with the range defined by f<sub>PLL\_OUT</sub>.
2. Guaranteed by design, not tested in production.

### 6.3.10 Memory characteristics

#### Flash memory

The characteristics are given at T<sub>A</sub> = -40 to 85 °C unless otherwise specified.

Table 37. Flash memory characteristics

Symbol	Parameter	Conditions	Min	Typ	Max <sup>(1)</sup>	Unit
t <sub>prog</sub>	16-bit programming time	T <sub>A</sub> = -40 to +85 °C	-	53.5	-	μs
t <sub>ERASE</sub>	Page (1 KB) erase time	T <sub>A</sub> = -40 to +85 °C	-	30	-	ms
t <sub>ME</sub>	Mass erase time	T <sub>A</sub> = -40 to +85 °C	-	30	-	ms
I <sub>DD</sub>	Supply current	Write mode	-	-	10	mA
		Erase mode	-	-	12	mA
V <sub>prog</sub>	Programming voltage		2.4	-	3.6	V

1. Guaranteed by design, not tested in production.

Table 38. Flash memory endurance and data retention

Symbol	Parameter	Conditions	Min <sup>(1)</sup>	Unit
N <sub>END</sub>	Endurance	T <sub>A</sub> = -40 to +85 °C (6 suffix versions)	1	kcycles
t <sub>RET</sub>	Data retention	1 kcycle <sup>(2)</sup> at T <sub>A</sub> = 85 °C	20	Years

1. Data based on characterization results, not tested in production.
2. Cycling performed over the whole temperature range.

### 6.3.11 EMC characteristics

Susceptibility tests are performed on a sample basis during device characterization.

### Functional EMS (electromagnetic susceptibility)

While a simple application is executed on the device (toggling 2 LEDs through I/O ports), the device is stressed by two electromagnetic events until a failure occurs. The failure is indicated by the LEDs:

- **Electrostatic discharge (ESD)** (positive and negative) is applied to all device pins until a functional disturbance occurs. This test is compliant with the IEC 61000-4-2 standard.
- **FTB:** A Burst of Fast Transient voltage (positive and negative) is applied to  $V_{DD}$  and  $V_{SS}$  through a 100 pF capacitor, until a functional disturbance occurs. This test is compliant with the IEC 61000-4-4 standard.

A device reset allows normal operations to be resumed.

The test results are given in [Table 39](#). They are based on the EMS levels and classes defined in application note AN1709.

**Table 39. EMS characteristics**

Symbol	Parameter	Conditions	Level/Class
$V_{FESD}$	Voltage limits to be applied on any I/O pin to induce a functional disturbance	$V_{DD} = 3.3\text{ V}$ , LQFP64, $T_A = +25\text{ °C}$ , $f_{HCLK} = 48\text{ MHz}$ conforms to IEC 61000-4-2	2B
$V_{EFTB}$	Fast transient voltage burst limits to be applied through 100 pF on $V_{DD}$ and $V_{SS}$ pins to induce a functional disturbance	$V_{DD} = 3.3\text{ V}$ , LQFP64, $T_A = +25\text{ °C}$ , $f_{HCLK} = 48\text{ MHz}$ conforms to IEC 61000-4-4	3B

### Designing hardened software to avoid noise problems

EMC characterization and optimization are performed at component level with a typical application environment and simplified MCU software. It should be noted that good EMC performance is highly dependent on the user application and the software in particular.

Therefore it is recommended that the user applies EMC software optimization and prequalification tests in relation with the EMC level requested for his application.

#### Software recommendations

The software flowchart must include the management of runaway conditions such as:

- Corrupted program counter
- Unexpected reset
- Critical Data corruption (control registers...)

#### Prequalification trials

Most of the common failures (unexpected reset and program counter corruption) can be reproduced by manually forcing a low state on the NRST pin or the Oscillator pins for 1 second.

To complete these trials, ESD stress can be applied directly on the device, over the range of specification values. When unexpected behavior is detected, the software can be hardened to prevent unrecoverable errors occurring (see application note AN1015).

### Electromagnetic Interference (EMI)

The electromagnetic field emitted by the device are monitored while a simple application is executed (toggling 2 LEDs through the I/O ports). This emission test is compliant with IEC 61967-2 standard which specifies the test board and the pin loading.

**Table 40. EMI characteristics**

Symbol	Parameter	Conditions	Monitored frequency band	Max vs. [ $f_{HSE}/f_{HCLK}$ ]	Unit
				8/48 MHz	
$S_{EMI}$	Peak level	$V_{DD} = 3.6\text{ V}$ , $T_A = 25\text{ }^\circ\text{C}$ , LQFP64 package compliant with IEC 61967-2	0.1 to 30 MHz	-3	dB $\mu$ V
			30 to 130 MHz	28	
			130 MHz to 1GHz	23	
			SAE EMI Level	4	-

### 6.3.12 Electrical sensitivity characteristics

Based on three different tests (ESD, LU) using specific measurement methods, the device is stressed in order to determine its performance in terms of electrical sensitivity.

#### Electrostatic discharge (ESD)

Electrostatic discharges (a positive then a negative pulse separated by 1 second) are applied to the pins of each sample according to each pin combination. The sample size depends on the number of supply pins in the device (3 parts  $\times$  (n+1) supply pins). This test conforms to the JESD22-A114/C101 standard.

**Table 41. ESD absolute maximum ratings**

Symbol	Ratings	Conditions	Class	Maximum value <sup>(1)</sup>	Unit
$V_{ESD(HBM)}$	Electrostatic discharge voltage (human body model)	$T_A = +25\text{ }^\circ\text{C}$ , conforming to JESD22-A114	2	2000	V
$V_{ESD(CDM)}$	Electrostatic discharge voltage (charge device model)	$T_A = +25\text{ }^\circ\text{C}$ , conforming to JESD22-C101	II	500	

1. Data based on characterization results, not tested in production.

#### Static latch-up

Two complementary static tests are required on six parts to assess the latch-up performance:

- A supply overvoltage is applied to each power supply pin
- A current injection is applied to each input, output and configurable I/O pin

These tests are compliant with EIA/JESD 78A IC latch-up standard.

**Table 42. Electrical sensitivities**

Symbol	Parameter	Conditions	Class
LU	Static latch-up class	$T_A = +105\text{ }^\circ\text{C}$ conforming to JESD78A	II level A



### 6.3.13 I/O current injection characteristics

As a general rule, current injection to the I/O pins, due to external voltage below  $V_{SS}$  or above  $V_{DD}$  (for standard, 3 V-capable I/O pins) should be avoided during normal product operation. However, in order to give an indication of the robustness of the microcontroller in cases when abnormal injection accidentally happens, susceptibility tests are performed on a sample basis during device characterization.

#### Functional susceptibility to I/O current injection

While a simple application is executed on the device, the device is stressed by injecting current into the I/O pins programmed in floating input mode. While current is injected into the I/O pin, one at a time, the device is checked for functional failures.

The failure is indicated by an out of range parameter: ADC error above a certain limit (more than 5 LSB TUE), out of conventional limits of current injection on adjacent pins (more than  $-5 \mu\text{A}$ ) or other functional failure (reset occurrence or oscillator frequency deviation, for example).

The characterization results are given in [Table 43](#).

**Table 43. I/O current injection susceptibility**

Symbol	Description	Functional susceptibility		Unit
		Negative injection	Positive injection	
$I_{INJ}$	Injected current on BOOT0	-0	NA	mA
	Injected current on all FT and FTf pins with induced leakage current on adjacent pins less than $-5 \mu\text{A}$	-5	NA	
	Injected current on all TTa pins with induced leakage current on adjacent pins less than $-5 \mu\text{A}$	-5	+5	
	Injected current on all TC and RESET pins with induced leakage current on adjacent pins less than $-5 \mu\text{A}$	-5	+5	

### 6.3.14 I/O port characteristics

#### General input/output characteristics

Unless otherwise specified, the parameters given in [Table 44](#) are derived from tests performed under the conditions summarized in [Table 18: General operating conditions](#). All I/Os are designed as CMOS and TTL compliant.

**Table 44. I/O static characteristics**

Symbol	Parameter	Conditions	Min	Typ	Max	Unit
$V_{IL}$	Low level input voltage	TC and TTa I/O	-	-	$0.3 V_{DD} + 0.07^{(1)}$	V
		FT and FTf I/O	-	-	$0.475 V_{DD} - 0.2^{(1)}$	
		BOOT0	-	-	$0.3 V_{DD} - 0.3^{(1)}$	
		All I/Os except BOOT0 pin	-	-	$0.3 V_{DD}$	

Table 44. I/O static characteristics (continued)

Symbol	Parameter	Conditions	Min	Typ	Max	Unit
$V_{IH}$	High level input voltage	TC and TTA I/O	$0.445 V_{DD} + 0.398^{(1)}$	-	-	V
		FT and FTf I/O	$0.5 V_{DD} + 0.2^{(1)}$	-	-	
		BOOT0	$0.2 V_{DD} + 0.95^{(1)}$	-	-	
		All I/Os except BOOT0 pin	$0.7 V_{DD}$	-	-	
$V_{hys}$	Schmitt trigger hysteresis	TC and TTA I/O	-	200 <sup>(1)</sup>	-	mV
		FT and FTf I/O	-	100 <sup>(1)</sup>	-	
		BOOT0	-	300 <sup>(1)</sup>	-	
$I_{lkg}$	Input leakage current <sup>(2)</sup>	TC, FT and FTf I/O TTa in digital mode $V_{SS} \leq V_{IN} \leq V_{DD}$	-	-	$\pm 0.1$	$\mu A$
		TTa in digital mode $V_{DD} \leq V_{IN} \leq V_{DDA}$	-	-	1	
		TTa in analog mode $V_{SS} \leq V_{IN} \leq V_{DDA}$	-	-	$\pm 0.2$	
		FT and FTf I/O <sup>(3)</sup> $V_{DD} \leq V_{IN} \leq 5 V$	-	-	10	
$R_{PU}$	Weak pull-up equivalent resistor <sup>(4)</sup>	$V_{IN} = V_{SS}$	25	40	55	k $\Omega$
$R_{PD}$	Weak pull-down equivalent resistor <sup>(4)</sup>	$V_{IN} = V_{DD}$	25	40	55	k $\Omega$
$C_{IO}$	I/O pin capacitance		-	5	-	pF

1. Data based on design simulation only. Not tested in production.
2. Leakage could be higher than maximum value, if negative current is injected on adjacent pins. Refer to [Table 43: I/O current injection susceptibility](#).
3. To sustain a voltage higher than  $V_{DD} + 0.3 V$ , the internal pull-up/pull-down resistors must be disabled.
4. Pull-up and pull-down resistors are designed with a true resistance in series with a switchable PMOS/NMOS. This MOS/NMOS contribution to the series resistance is minimum (~10% order).

All I/Os are CMOS and TTL compliant (no software configuration required). Their characteristics cover more than the strict CMOS-technology or TTL parameters. The coverage of these requirements is shown in [Figure 16](#) for standard I/Os, and in [Figure 17](#) for 5 V tolerant I/Os.

Figure 16. TC and TTa I/O input characteristics

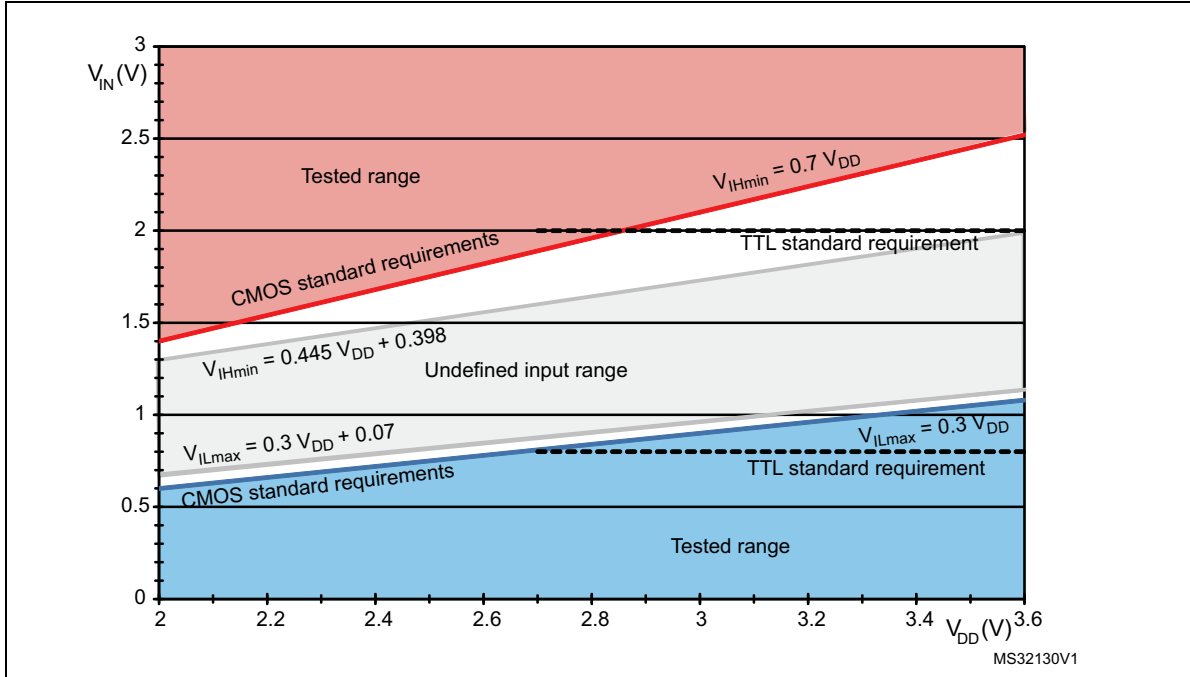
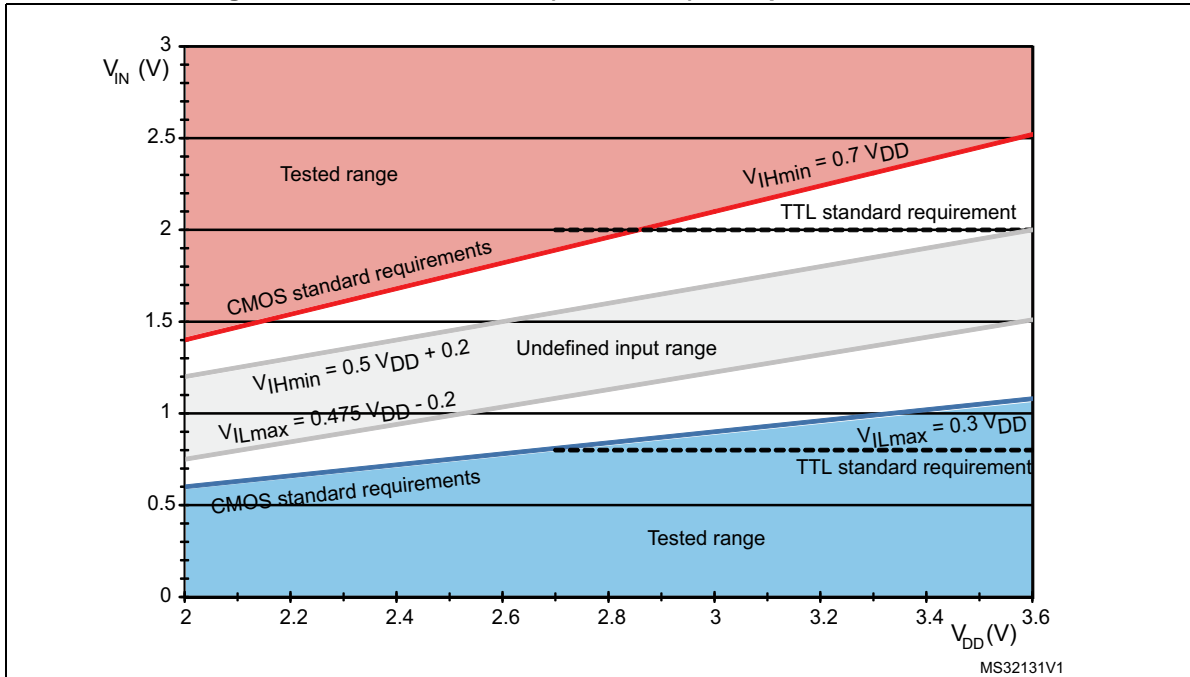


Figure 17. Five volt tolerant (FT and FTf) I/O input characteristics



### Output driving current

The GPIOs (general purpose input/outputs) can sink or source up to +/-8 mA, and sink or source up to +/- 20 mA (with a relaxed  $V_{OL}/V_{OH}$ ).

In the user application, the number of I/O pins which can drive current must be limited to respect the absolute maximum rating specified in [Section 6.2](#):

- The sum of the currents sourced by all the I/Os on  $V_{DD}$ , plus the maximum Run consumption of the MCU sourced on  $V_{DD}$ , cannot exceed the absolute maximum rating  $\Sigma I_{VDD}$  (see [Table 16: Current characteristics](#)).
- The sum of the currents sunk by all the I/Os on  $V_{SS}$  plus the maximum Run consumption of the MCU sunk on  $V_{SS}$  cannot exceed the absolute maximum rating  $\Sigma I_{VSS}$  (see [Table 16: Current characteristics](#)).

### Output voltage levels

Unless otherwise specified, the parameters given in the table below are derived from tests performed under ambient temperature and  $V_{DD}$  supply voltage conditions summarized in [Table 18: General operating conditions](#). All I/Os are CMOS and TTL compliant (FT, TTA or TC unless otherwise specified).

**Table 45. Output voltage characteristics**

Symbol	Parameter	Conditions	Min	Max	Unit
$V_{OL}^{(1)}$	Output low level voltage for an I/O pin when 8 pins are sunk at the same time	$I_{IO} = +8 \text{ mA}$ $2.7 \text{ V} < V_{DD} < 3.6 \text{ V}$	-	0.4	V
$V_{OH}^{(2)}$	Output high level voltage for an I/O pin when 8 pins are sourced at the same time		$V_{DD}-0.4$	-	
$V_{OL}^{(1)(3)}$	Output low level voltage for an I/O pin when 5 pins are sunk at the same time	$I_{IO} = +20 \text{ mA}$ $2.7 \text{ V} < V_{DD} < 3.6 \text{ V}$	-	1.3	V
$V_{OH}^{(2)(3)}$	Output high level voltage for an I/O pin when 5 pins are sourced at the same time		$V_{DD}-1.3$	-	
$V_{OL}^{(1)(3)}$	Output low level voltage for an I/O pin when 8 pins are sunk at the same time	$I_{IO} = +6 \text{ mA}$ $2.4 \text{ V} < V_{DD} < 2.7 \text{ V}$	-	0.4	V
$V_{OH}^{(2)(3)}$	Output high level voltage for an I/O pin when 8 pins are sourced at the same time		$V_{DD}-0.4$	-	
$V_{OLFM+}^{(1)}$	Output low level voltage for an FTf I/O pin in FM+ mode	$I_{IO} = +20 \text{ mA}$	-	0.4	V

1. The  $I_{IO}$  current sunk by the device must always respect the absolute maximum rating specified in [Table 16: Current characteristics](#) and the sum of  $I_{IO}$  (I/O ports and control pins) must not exceed  $I_{VSS}$ .
2. The  $I_{IO}$  current sourced by the device must always respect the absolute maximum rating specified in [Table 16: Current characteristics](#) and the sum of  $I_{IO}$  (I/O ports and control pins) must not exceed  $I_{VDD}$ .
3. Data based on characterization results. Not tested in production.

### Input/output AC characteristics

The definition and values of input/output AC characteristics are given in [Figure 18](#) and [Table 46](#), respectively.

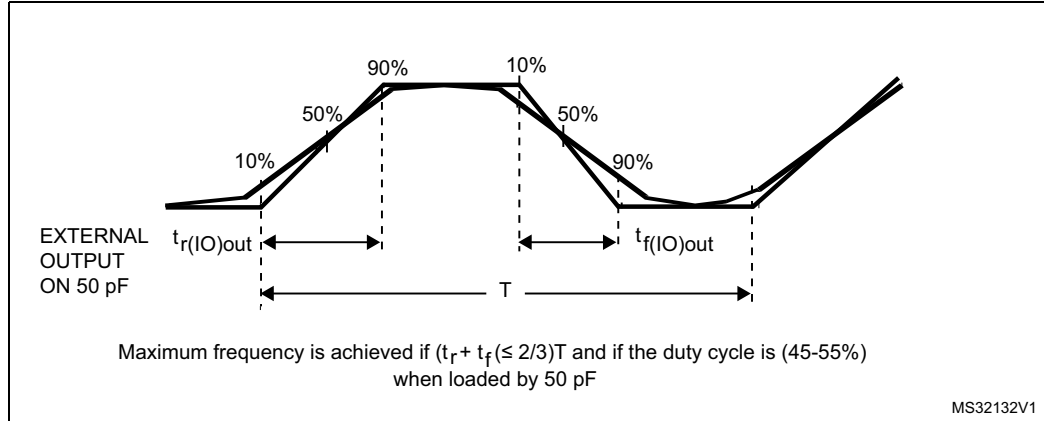
Unless otherwise specified, the parameters given are derived from tests performed under ambient temperature and  $V_{DD}$  supply voltage conditions summarized in [Table 18: General operating conditions](#).

**Table 46. I/O AC characteristics<sup>(1)</sup>**

OSPEEDRy [1:0] value <sup>(1)</sup>	Symbol	Parameter	Conditions	Min	Max	Unit
x0	$f_{\max(\text{IO})\text{out}}$	Maximum frequency <sup>(2)</sup>	$C_L = 50 \text{ pF}$ , $V_{DD} = 2.4 \text{ V to } 3.6 \text{ V}$	-	2	MHz
	$t_{f(\text{IO})\text{out}}$	Output high to low level fall time	$C_L = 50 \text{ pF}$ , $V_{DD} = 2.4 \text{ V to } 3.6 \text{ V}$	-	125 <sup>(3)</sup>	ns
	$t_{r(\text{IO})\text{out}}$	Output low to high level rise time		-	125 <sup>(3)</sup>	
01	$f_{\max(\text{IO})\text{out}}$	Maximum frequency <sup>(2)</sup>	$C_L = 50 \text{ pF}$ , $V_{DD} = 2.4 \text{ V to } 3.6 \text{ V}$	-	10	MHz
	$t_{f(\text{IO})\text{out}}$	Output high to low level fall time	$C_L = 50 \text{ pF}$ , $V_{DD} = 2.4 \text{ V to } 3.6 \text{ V}$	-	25 <sup>(3)</sup>	ns
	$t_{r(\text{IO})\text{out}}$	Output low to high level rise time		-	25 <sup>(3)</sup>	
11	$f_{\max(\text{IO})\text{out}}$	Maximum frequency <sup>(2)</sup>	$C_L = 30 \text{ pF}$ , $V_{DD} = 2.7 \text{ V to } 3.6 \text{ V}$	-	50	MHz
			$C_L = 50 \text{ pF}$ , $V_{DD} = 2.7 \text{ V to } 3.6 \text{ V}$	-	30	
			$C_L = 50 \text{ pF}$ , $V_{DD} = 2.4 \text{ V to } 2.7 \text{ V}$	-	20	
	$t_{f(\text{IO})\text{out}}$	Output high to low level fall time	$C_L = 30 \text{ pF}$ , $V_{DD} = 2.7 \text{ V to } 3.6 \text{ V}$	-	5 <sup>(3)</sup>	ns
			$C_L = 50 \text{ pF}$ , $V_{DD} = 2.7 \text{ V to } 3.6 \text{ V}$	-	8 <sup>(3)</sup>	
	$t_{r(\text{IO})\text{out}}$	Output low to high level rise time	$C_L = 30 \text{ pF}$ , $V_{DD} = 2.7 \text{ V to } 3.6 \text{ V}$	-	5 <sup>(3)</sup>	
$C_L = 50 \text{ pF}$ , $V_{DD} = 2.7 \text{ V to } 3.6 \text{ V}$			-	8 <sup>(3)</sup>		
FM+ configuration <sup>(4)</sup>	$f_{\max(\text{IO})\text{out}}$	Maximum frequency <sup>(2)</sup>	$C_L = 50 \text{ pF}$ , $V_{DD} = 2.4 \text{ V to } 3.6 \text{ V}$	-	2 <sup>(3)</sup>	MHz
	$t_{f(\text{IO})\text{out}}$	Output high to low level fall time	$C_L = 50 \text{ pF}$ , $V_{DD} = 2.4 \text{ V to } 3.6 \text{ V}$	-	12 <sup>(3)</sup>	ns
	$t_{r(\text{IO})\text{out}}$	Output low to high level rise time	$C_L = 50 \text{ pF}$ , $V_{DD} = 2.4 \text{ V to } 3.6 \text{ V}$	-	34 <sup>(3)</sup>	
	$t_{\text{EXTI}pw}$	Pulse width of external signals detected by the EXTI controller		10	-	ns

1. The I/O speed is configured using the OSPEEDRx[1:0] bits. Refer to the RM0091 reference manual for a description of GPIO Port configuration register.
2. The maximum frequency is defined in [Figure 18](#).
3. Guaranteed by design, not tested in production.
4. When FM+ configuration is set, the I/O speed control is bypassed. Refer to the STM32F0xx reference manual RM0091 for a detailed description of FM+ I/O configuration.

Figure 18. I/O AC characteristics definition



### 6.3.15 NRST pin characteristics

The NRST pin input driver uses the CMOS technology. It is connected to a permanent pull-up resistor,  $R_{PU}$  (see [Table 44: I/O static characteristics](#)).

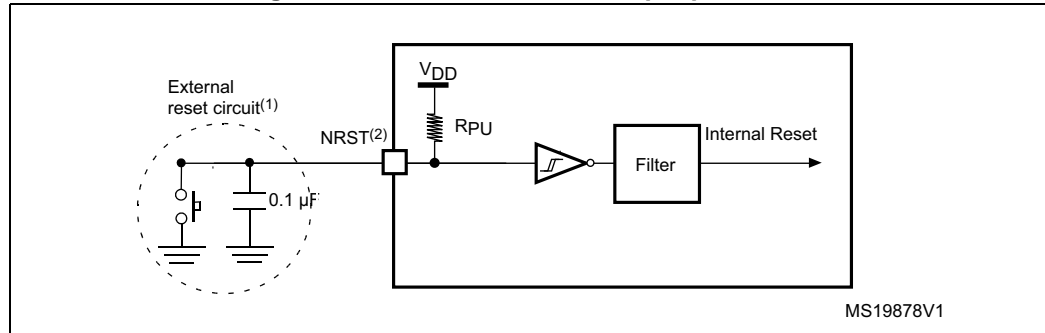
Unless otherwise specified, the parameters given in the table below are derived from tests performed under ambient temperature and VDD supply voltage conditions summarized in [Table 18: General operating conditions](#).

Table 47. NRST pin characteristics

Symbol	Parameter	Conditions	Min	Typ	Max	Unit
$V_{IL(NRST)}$	NRST input low level voltage		-0.3	-	$0.8^{(1)}$	V
$V_{IH(NRST)}$	NRST input high level voltage		2	-	$V_{DD} + 0.3^{(1)}$	
$V_{hys(NRST)}$	NRST Schmitt trigger voltage hysteresis		-	200	-	mV
$R_{PU}$	Weak pull-up equivalent resistor <sup>(2)</sup>	$V_{IN} = V_{SS}$	30	40	50	k $\Omega$
$V_{F(NRST)}$	NRST input filtered pulse		-	-	$100^{(1)}$	ns
$V_{NF(NRST)}$	NRST input not filtered pulse		$300^{(1)}$	-	-	ns

1. Guaranteed by design, not tested in production.
2. The pull-up is designed with a true resistance in series with a switchable PMOS. This PMOS contribution to the series resistance must be minimum (~10% order).

Figure 19. Recommended NRST pin protection



1. The reset network protects the device against parasitic resets.
2. The user must ensure that the level on the NRST pin can go below the  $V_{IL(NRST)}$  max level specified in [Table 47: NRST pin characteristics](#). Otherwise the reset will not be taken into account by the device.

### 6.3.16 12-bit ADC characteristics

Unless otherwise specified, the parameters given in [Table 48](#) are preliminary values derived from tests performed under ambient temperature,  $f_{PCLK2}$  frequency and  $V_{DDA}$  supply voltage conditions summarized in [Table 18: General operating conditions](#).

Note: It is recommended to perform a calibration after each power-up.

**Table 48. ADC characteristics**

Symbol	Parameter	Conditions	Min	Typ	Max	Unit
$V_{DDA}$	Analog supply voltage for ADC ON		2.4	-	3.6	V
$f_{ADC}$	ADC clock frequency		0.6	-	14	MHz
$f_S^{(1)}$	Sampling rate		0.05	-	1	MHz
$f_{TRIG}^{(1)}$	External trigger frequency	$f_{ADC} = 14$ MHz	-	-	823	kHz
			-	-	17	$1/f_{ADC}$
$V_{AIN}$	Conversion voltage range		0	-	$V_{DDA}$	V
$R_{AIN}^{(1)}$	External input impedance	See <a href="#">Equation 1</a> and <a href="#">Table 49</a> for details	-	-	50	k $\Omega$
$R_{ADC}^{(1)}$	Sampling switch resistance		-	-	1	k $\Omega$
$C_{ADC}^{(1)}$	Internal sample and hold capacitor		-	-	8	pF
$t_{CAL}^{(1)}$	Calibration time	$f_{ADC} = 14$ MHz	5.9			$\mu$ s
			83			$1/f_{ADC}$
$t_{latr}^{(1)}$	Trigger conversion latency	$f_{ADC} = f_{PCLK}/2 = 14$ MHz	0.196			$\mu$ s
		$f_{ADC} = f_{PCLK}/2$	5.5			$1/f_{PCLK}$
		$f_{ADC} = f_{PCLK}/4 = 12$ MHz	0.219			$\mu$ s
		$f_{ADC} = f_{PCLK}/4$	10.5			$1/f_{PCLK}$
		$f_{ADC} = f_{HSI14} = 14$ MHz	0.188	-	0.259	$\mu$ s
Jitter <sub>ADC</sub>	ADC jitter on trigger conversion	$f_{ADC} = f_{HSI14}$	-	1	-	$1/f_{HSI14}$
$t_S^{(1)}$	Sampling time	$f_{ADC} = 14$ MHz	0.107	-	17.1	$\mu$ s
			1.5	-	239.5	$1/f_{ADC}$
$t_{STAB}^{(1)}$	Power-up time		0	0	1	$\mu$ s
$t_{CONV}^{(1)}$	Total conversion time (including sampling time)	$f_{ADC} = 14$ MHz	1	-	18	$\mu$ s
			14 to 252 ( $t_S$ for sampling +12.5 for successive approximation)			$1/f_{ADC}$

1. Guaranteed by design, not tested in production.



**Equation 1: R<sub>AIN</sub> max formula**

$$R_{AIN} < \frac{T_s}{f_{ADC} \times C_{ADC} \times \ln(2^{N+2})} - R_{ADC}$$

The formula above ([Equation 1](#)) is used to determine the maximum external impedance allowed for an error below 1/4 of LSB. Here N = 12 (from 12-bit resolution).

**Table 49. R<sub>AIN</sub> max for f<sub>ADC</sub> = 14 MHz**

T <sub>s</sub> (cycles)	t <sub>s</sub> (μs)	R <sub>AIN</sub> max (kΩ) <sup>(1)</sup>
1.5	0.11	0.4
7.5	0.54	5.9
13.5	0.96	11.4
28.5	2.04	25.2
41.5	2.96	37.2
55.5	3.96	50
71.5	5.11	NA
239.5	17.1	NA

1. Guaranteed by design, not tested in production.

**Table 50. ADC accuracy<sup>(1)(2)(3)</sup>**

Symbol	Parameter	Test conditions	Typ	Max <sup>(4)</sup>	Unit
ET	Total unadjusted error	f <sub>PCLK</sub> = 48 MHz, f <sub>ADC</sub> = 14 MHz, R <sub>AIN</sub> < 10 kΩ, V <sub>DDA</sub> = 2.7 V to 3.6 V T <sub>A</sub> = -40 to 85 °C	±3.3	±4	LSB
EO	Offset error		±1.9	±2.8	
EG	Gain error		±2.8	±3	
ED	Differential linearity error		±0.7	±1.3	
EL	Integral linearity error		±1.2	±1.7	

1. ADC DC accuracy values are measured after internal calibration.
2. ADC Accuracy vs. Negative Injection Current: Injecting negative current on any of the standard (non-robust) analog input pins should be avoided as this significantly reduces the accuracy of the conversion being performed on another analog input. It is recommended to add a Schottky diode (pin to ground) to standard analog pins which may potentially inject negative current. Any positive injection current within the limits specified for I<sub>INJ(PIN)</sub> and ΣI<sub>INJ(PIN)</sub> in [Section 6.3.14](#) does not affect the ADC accuracy.
3. Better performance may be achieved in restricted V<sub>DDA</sub>, frequency and temperature ranges.
4. Data based on characterization results, not tested in production.

Figure 20. ADC accuracy characteristics

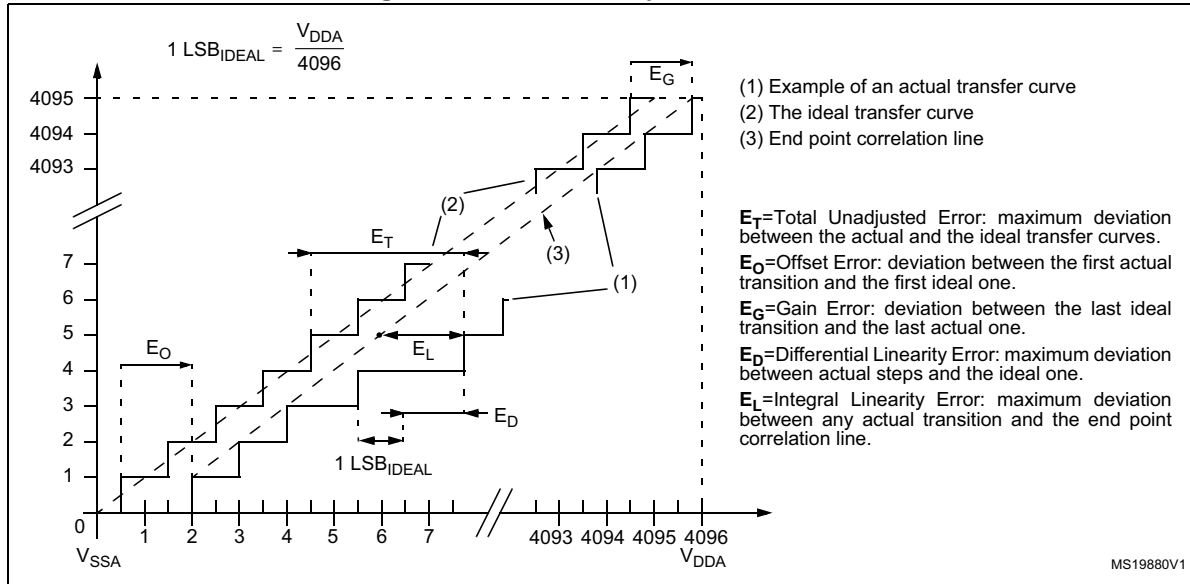
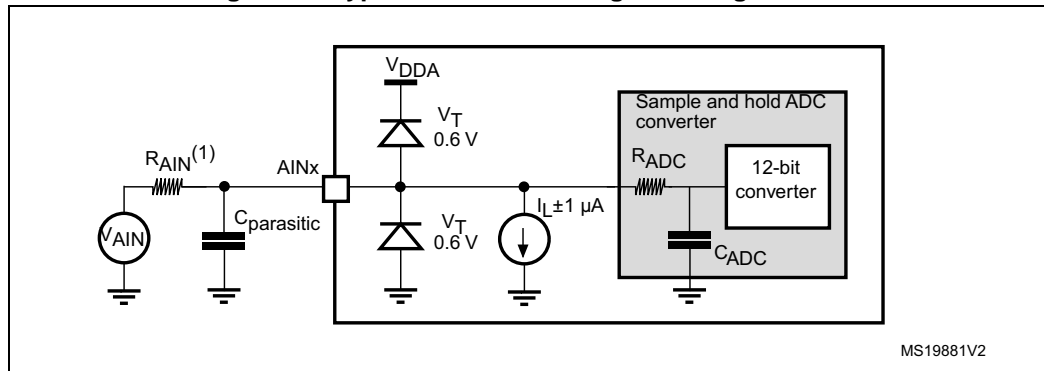


Figure 21. Typical connection diagram using the ADC



1. Refer to [Table 48: ADC characteristics](#) for the values of  $R_{\text{AIN}}$ ,  $R_{\text{ADC}}$  and  $C_{\text{ADC}}$ .
2.  $C_{\text{parasitic}}$  represents the capacitance of the PCB (dependent on soldering and PCB layout quality) plus the pad capacitance (roughly 7 pF). A high  $C_{\text{parasitic}}$  value will downgrade conversion accuracy. To remedy this,  $f_{\text{ADC}}$  should be reduced.

**General PCB design guidelines**

Power supply decoupling should be performed as shown in [Figure 10: Power supply scheme](#). The 10 nF capacitor should be ceramic (good quality) and it should be placed as close as possible to the chip.

### 6.3.17 Temperature sensor characteristics

**Table 51. TS characteristics**

Symbol	Parameter	Min	Typ	Max	Unit
$T_L^{(1)}$	$V_{SENSE}$ linearity with temperature	-	$\pm 1$	$\pm 2$	$^{\circ}\text{C}$
Avg_Slope <sup>(1)</sup>	Average slope	4.0	4.3	4.6	mV/ $^{\circ}\text{C}$
$V_{25}$	Voltage at 25 $^{\circ}\text{C}$	1.34	1.43	1.52	V
$t_{START}^{(1)}$	Startup time	4	-	10	$\mu\text{s}$
$T_{S\_temp}^{(1)(2)}$	ADC sampling time when reading the temperature	17.1	-	-	$\mu\text{s}$

1. Guaranteed by design, not tested in production.
2. Shortest sampling time can be determined in the application by multiple iterations.

### 6.3.18 Timer characteristics

The parameters given in [Table 52](#) are guaranteed by design.

Refer to [Section 6.3.14: I/O port characteristics](#) for details on the input/output alternate function characteristics (output compare, input capture, external clock, PWM output).

**Table 52. TIMx<sup>(1)</sup> characteristics**

Symbol	Parameter	Conditions	Min	Max	Unit
$t_{res(TIM)}$	Timer resolution time		1	-	$t_{TIMxCLK}$
		$f_{TIMxCLK} = 48\text{ MHz}$	20.8	-	ns
$f_{EXT}$	Timer external clock frequency on CH1 to CH4		0	$f_{TIMxCLK}/2$	MHz
		$f_{TIMxCLK} = 48\text{ MHz}$	0	24	MHz
$Res_{TIM}$	Timer resolution	TIMx	-	16	bit
$t_{COUNTER}$	16-bit counter clock period		1	65536	$t_{TIMxCLK}$
		$f_{TIMxCLK} = 48\text{ MHz}$	0.0208	1365	$\mu\text{s}$
$t_{MAX\_COUNT}$	Maximum possible count with 32-bit counter		-	$65536 \times 65536$	$t_{TIMxCLK}$
		$f_{TIMxCLK} = 48\text{ MHz}$	-	89.48	s

1. TIMx is used as a general term to refer to the TIM1, TIM3, TIM6, TIM14, TIM15, TIM16 and TIM17 timers.

Table 53. IWDG min/max timeout period at 40 kHz (LSI) <sup>(1)</sup>

Prescaler divider	PR[2:0] bits	Min timeout RL[11:0]= 0x000	Max timeout RL[11:0]= 0xFFFF	Unit
/4	0	0.1	409.6	ms
/8	1	0.2	819.2	
/16	2	0.4	1638.4	
/32	3	0.8	3276.8	
/64	4	1.6	6553.6	
/128	5	3.2	13107.2	
/256	6 or 7	6.4	26214.4	

1. These timings are given for a 40 kHz clock but the microcontroller's internal RC frequency can vary from 30 to 60 kHz. Moreover, given an exact RC oscillator frequency, the exact timings still depend on the phasing of the APB interface clock versus the LSI clock so that there is always a full RC period of uncertainty.

Table 54. WWDG min-max timeout value @48 MHz (PCLK)

Prescaler	WDGTB	Min timeout value	Max timeout value	Unit
1	0	0.0853	5.4613	ms
2	1	0.1706	10.9226	
4	2	0.3413	21.8453	
8	3	0.6826	43.6906	

### 6.3.19 Communication interfaces

#### I<sup>2</sup>C interface characteristics

The I<sup>2</sup>C interface meets the requirements of the standard I<sup>2</sup>C communication protocol with the following restrictions: the I/O pins SDA and SCL are mapped to are not “true” open-drain. When configured as open-drain, the PMOS connected between the I/O pin and V<sub>DD</sub> is disabled, but is still present.

The I<sup>2</sup>C characteristics are described in [Table 55](#). Refer also to [Section 6.3.14: I/O port characteristics](#) for more details on the input/output alternate function characteristics (SDA and SCL).

**Table 55. I2C characteristics<sup>(1)</sup>**

Symbol	Parameter	Standard		Fast mode		Fast mode +		Unit
		Min	Max	Min	Max	Min	Max	
f <sub>SCL</sub>	SCL clock frequency	0	100	0	400	0	1000	KHz
t <sub>LOW</sub>	Low period of the SCL clock	4.7	-	1.3	-	0.5	-	μs
t <sub>HIGH</sub>	High Period of the SCL clock	4	-	0.6	-	0.26	-	μs
t <sub>r</sub>	Rise time of both SDA and SCL signals	-	1000	-	300	-	120	ns
t <sub>f</sub>	Fall time of both SDA and SCL signals	-	300	-	300	-	120	ns
t <sub>HD;DAT</sub>	Data hold time	0	-	0	-	0	-	μs
t <sub>VD;DAT</sub>	Data valid time	-	3.45 <sup>(2)</sup>	-	0.9 <sup>(2)</sup>	-	0.45 <sup>(2)</sup>	μs
t <sub>VD;ACK</sub>	Data valid acknowledge time	-	3.45 <sup>(2)</sup>	-	0.9 <sup>(2)</sup>	-	0.45 <sup>(2)</sup>	μs
t <sub>SU;DAT</sub>	Data setup time	250	-	100	-	50	-	ns
t <sub>HD;STA</sub>	Hold time (repeated) START condition	4.0	-	0.6	-	0.26	-	μs
t <sub>SU;STA</sub>	Set-up time for a repeated START condition	4.7	-	0.6	-	0.26	-	μs
t <sub>SU;STO</sub>	Set-up time for STOP condition	4.0	-	0.6	-	0.26	-	μs
t <sub>BUF</sub>	Bus free time between a STOP and START condition	4.7	-	1.3	-	0.5	-	μs
C <sub>b</sub>	Capacitive load for each bus line	-	400	-	400	-	550	pF

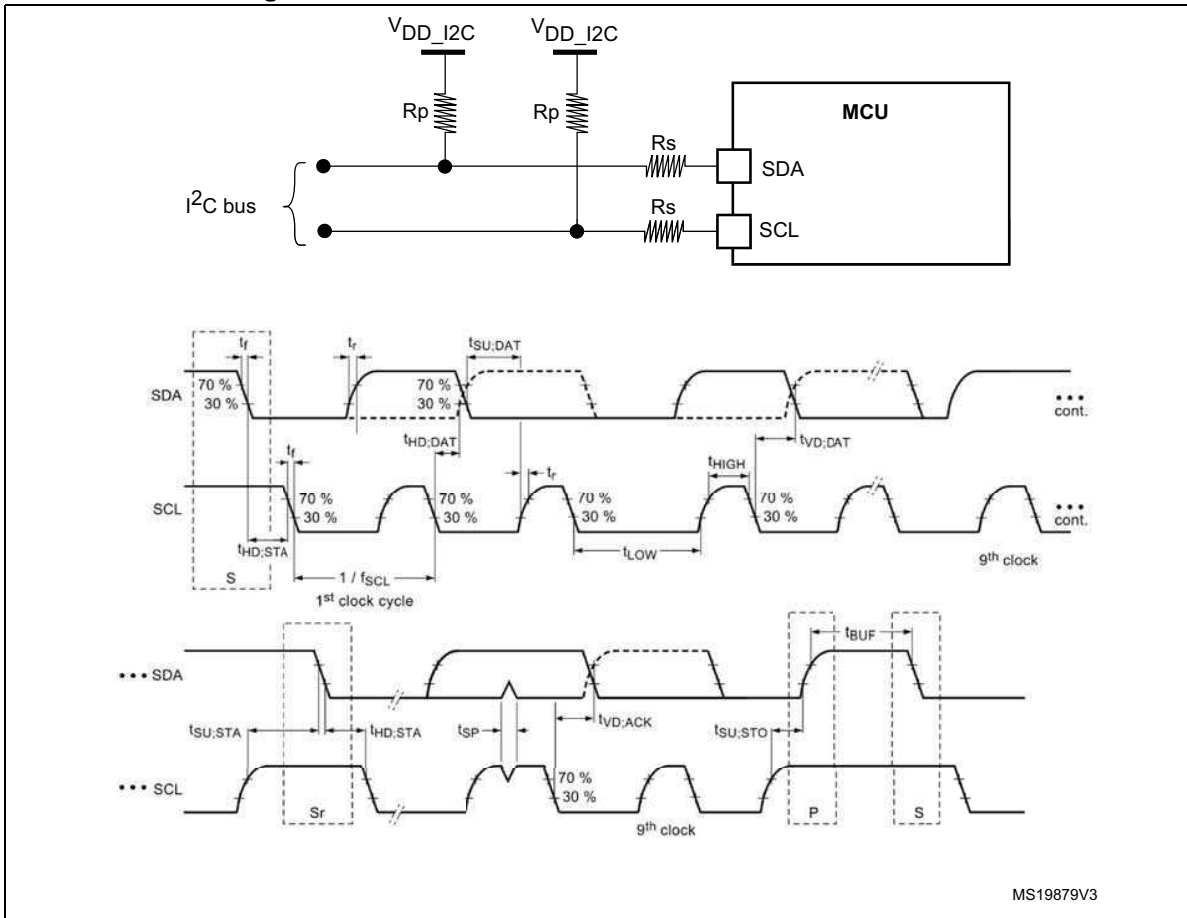
1. The I2C characteristics are the requirements from the I2C bus specification rev03. They are guaranteed by design when the I2Cx\_TIMING register is correctly programmed (refer to reference manual). These characteristics are not tested in production.
2. The maximum t<sub>HD;DAT</sub> could be 3.45 μs, 0.9 μs and 0.45 μs for standard mode, fast mode and fast mode plus, but must be less than the maximum of t<sub>VD;DAT</sub> or t<sub>VD;ACK</sub> by a transition time.

Table 56. I2C analog filter characteristics<sup>(1)</sup>

Symbol	Parameter	Min	Max	Unit
$t_{SP}$	Pulse width of spikes that are suppressed by the analog filter	50	260	ns

1. Guaranteed by design, not tested in production.

Figure 22. I2C bus AC waveforms and measurement circuit



Legend: Rs: Series protection resistors. Rp: Pull-up resistors.  $V_{DD\_I2C}$ : I2C bus supply.

**SPI characteristics**

Unless otherwise specified, the parameters given in [Table 57](#) are derived from tests performed under ambient temperature,  $f_{PCLKx}$  frequency and  $V_{DD}$  supply voltage conditions summarized in [Table 18: General operating conditions](#).

Refer to [Section 6.3.14: I/O port characteristics](#) for more details on the input/output alternate function characteristics (NSS, SCK, MOSI, MISO for SPI and WS, CK).

Table 57. SPI characteristics

Symbol	Parameter	Conditions	Min	Max	Unit
$f_{SCK}$ $1/t_{c(SCK)}$	SPI clock frequency	Master mode	-	18	MHz
		Slave mode	-	18	
$t_{r(SCK)}$ $t_{f(SCK)}$	SPI clock rise and fall time	Capacitive load: C = 15 pF	-	6	ns
$t_{su(NSS)}^{(1)}$	NSS setup time	Slave mode	4Tpclk	-	ns
$t_{h(NSS)}^{(1)}$	NSS hold time	Slave mode	2Tpclk + 10	-	
$t_{w(SCKH)}^{(1)}$ $t_{w(SCKL)}^{(1)}$	SCK high and low time	Master mode, $f_{PCLK} = 36$ MHz, presc = 4	Tpclk/2 - 2	Tpclk/2 + 1	
$t_{su(MI)}^{(1)}$ $t_{su(SI)}^{(1)}$	Data input setup time	Master mode	4	-	
		Slave mode	5	-	
$t_{h(MI)}^{(1)}$ $t_{h(SI)}^{(1)}$	Data input hold time	Master mode	4	-	
		Slave mode	5	-	
$t_{a(SO)}^{(1)(2)}$	Data output access time	Slave mode, $f_{PCLK} = 20$ MHz	0	3Tpclk	
$t_{dis(SO)}^{(1)(3)}$	Data output disable time	Slave mode	0	18	
$t_{v(SO)}^{(1)}$	Data output valid time	Slave mode (after enable edge)	-	22.5	
$t_{v(MO)}^{(1)}$	Data output valid time	Master mode (after enable edge)	-	6	
$t_{h(SO)}^{(1)}$ $t_{h(MO)}^{(1)}$	Data output hold time	Slave mode (after enable edge)	11.5	-	
		Master mode (after enable edge)	2	-	
DuCy(SCK)	SPI slave input clock duty cycle	Slave mode	25	75	%

1. Data based on characterization results, not tested in production.
2. Min time is for the minimum time to drive the output and the max time is for the maximum time to validate the data.
3. Min time is for the minimum time to invalidate the output and the max time is for the maximum time to put the data in Hi-Z

Figure 23. SPI timing diagram - slave mode and CPHA = 0

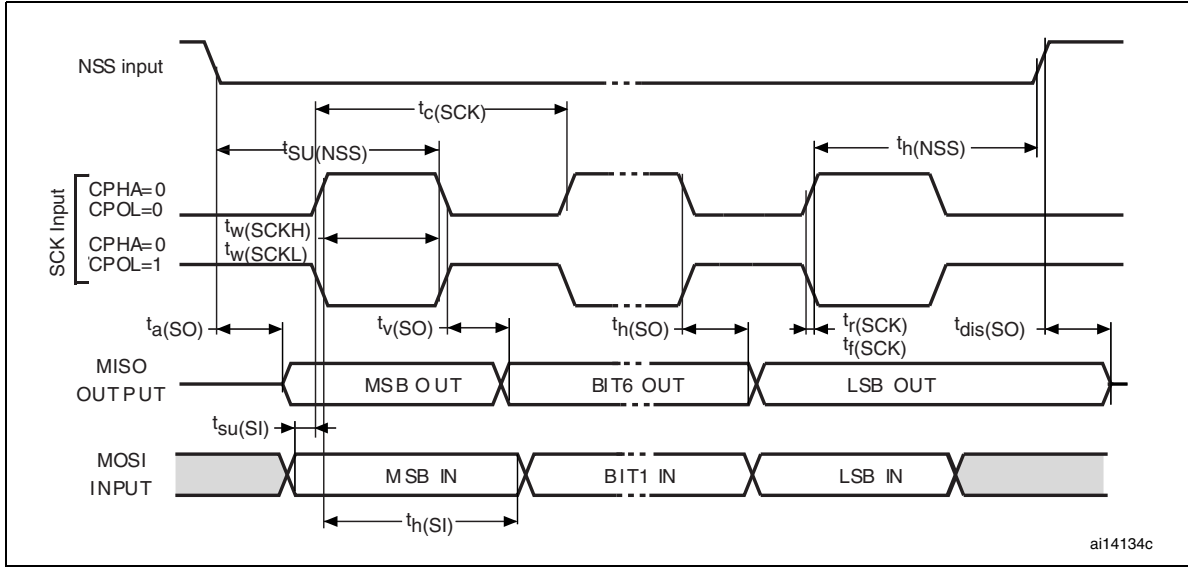
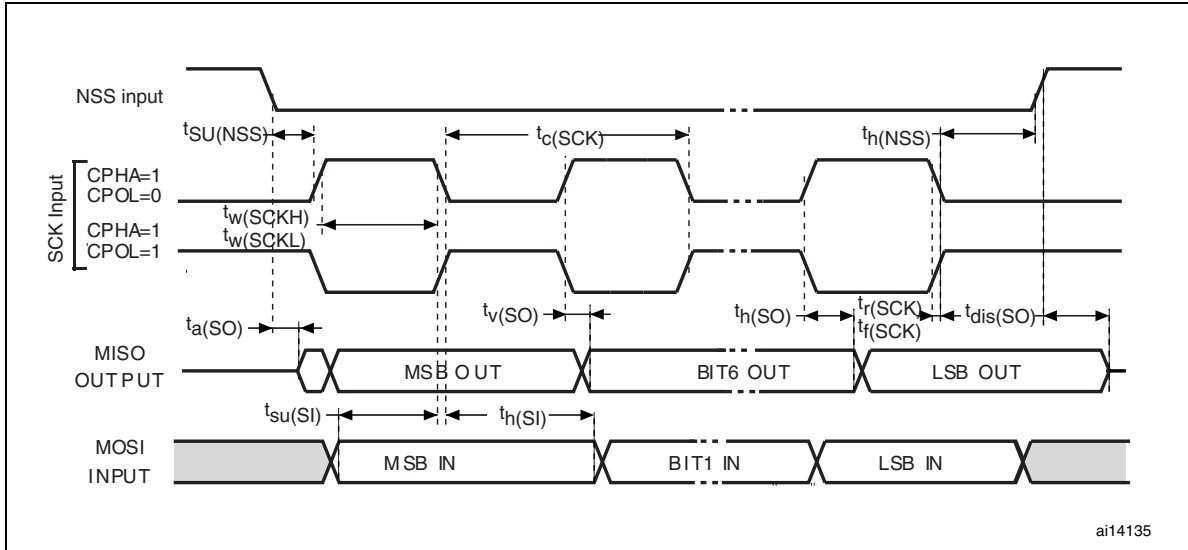


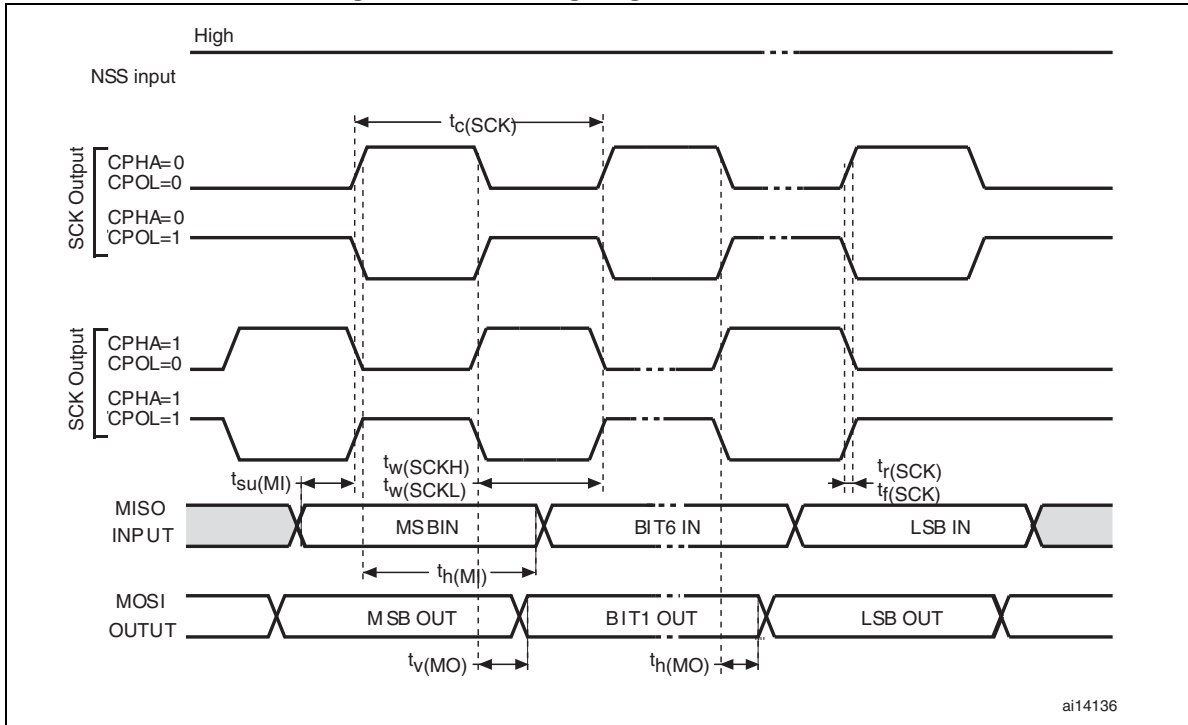
Figure 24. SPI timing diagram - slave mode and CPHA = 1



1. Measurement points are done at CMOS levels: 0.3V<sub>DD</sub> and 0.7V<sub>DD</sub>.



Figure 25. SPI timing diagram - master mode



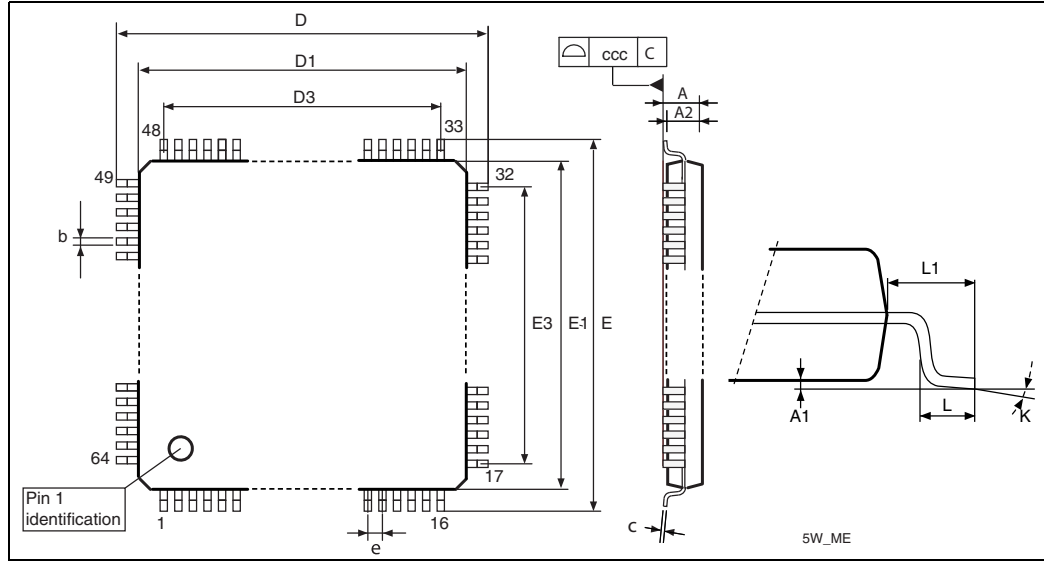
1. Measurement points are done at CMOS levels:  $0.3V_{DD}$  and  $0.7V_{DD}$ .

## 7 Package characteristics

### 7.1 Package mechanical data

In order to meet environmental requirements, ST offers these devices in different grades of ECOPACK<sup>®</sup> packages, depending on their level of environmental compliance. ECOPACK<sup>®</sup> specifications, grade definitions and product status are available at: [www.st.com](http://www.st.com). ECOPACK<sup>®</sup> is an ST trademark.

Figure 26. LQFP64 – 10 x 10 mm 64 pin low-profile quad flat package outline



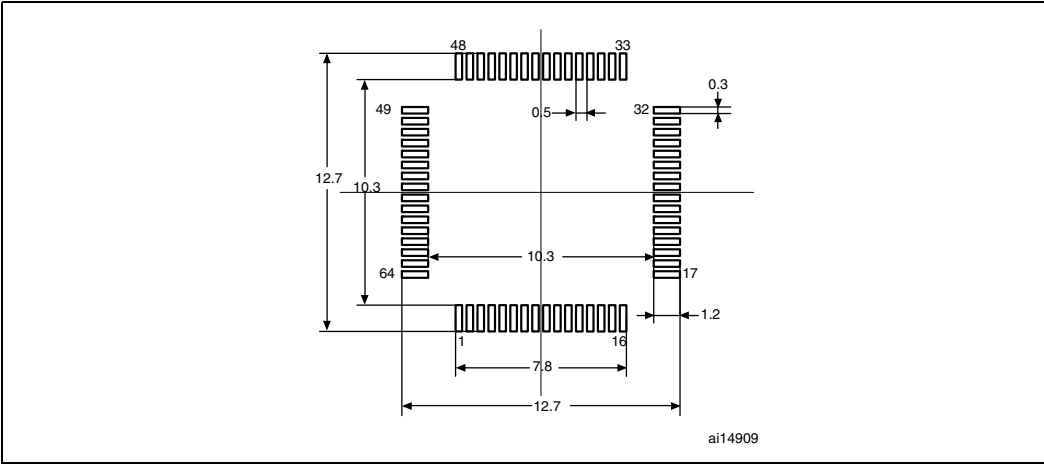
1. Drawing is not to scale.

Table 58. LQFP64 – 10 x 10 mm 64 pin low-profile quad flat package mechanical data

Symbol	millimeters			inches <sup>(1)</sup>		
	Min	Typ	Max	Min	Typ	Max
A			1.600			0.0630
A1	0.050		0.150	0.0020		0.0059
A2	1.350	1.400	1.450	0.0531	0.0551	0.0571
b	0.170	0.220	0.270	0.0067	0.0087	0.0106
c	0.090		0.200	0.0035		0.0079
D	11.800	12.000	12.200	0.4646	0.4724	0.4803
D1	9.800	10.000	10.200	0.3858	0.3937	0.4016
D.		7.500				
E	11.800	12.000	12.200	0.4646	0.4724	0.4803
E1	9.800	10.00	10.200	0.3858	0.3937	0.4016
e		0.500			0.0197	
k	0°	3.5°	7°	0°	3.5°	7°
L	0.450	0.600	0.75	0.0177	0.0236	0.0295
L1		1.000			0.0394	
ccc		0.080			0.0031	

1. Values in inches are converted from mm and rounded to 4 decimal digits.

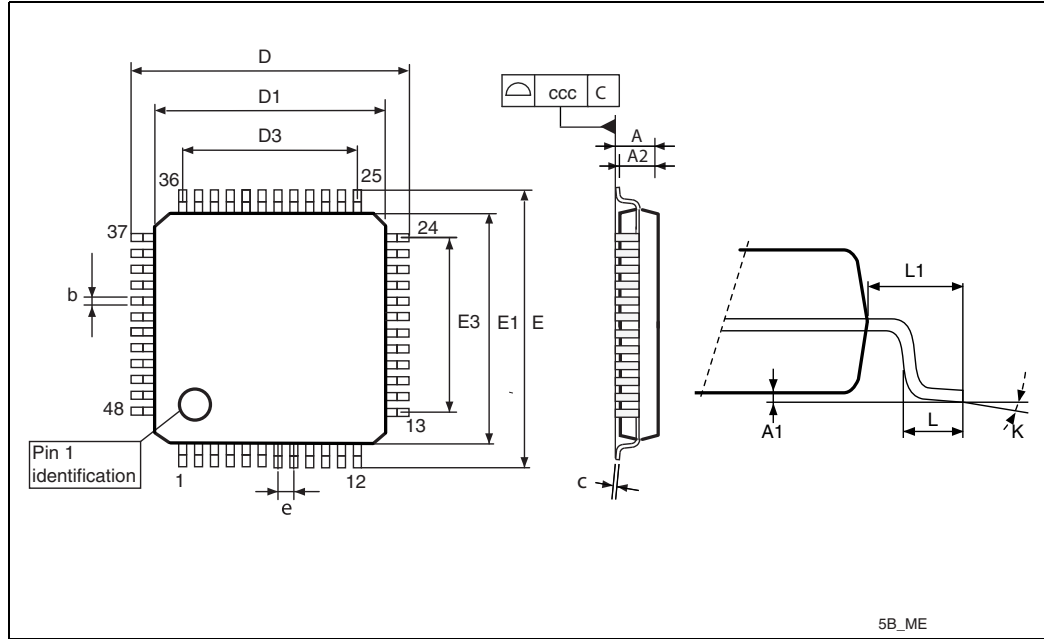
Figure 27. LQFP64 recommended footprint



- 1. Drawing is not to scale.
- 2. Dimensions are in millimeters.



Figure 28. LQFP48 – 7 x 7 mm, 48 pin low-profile quad flat package outline



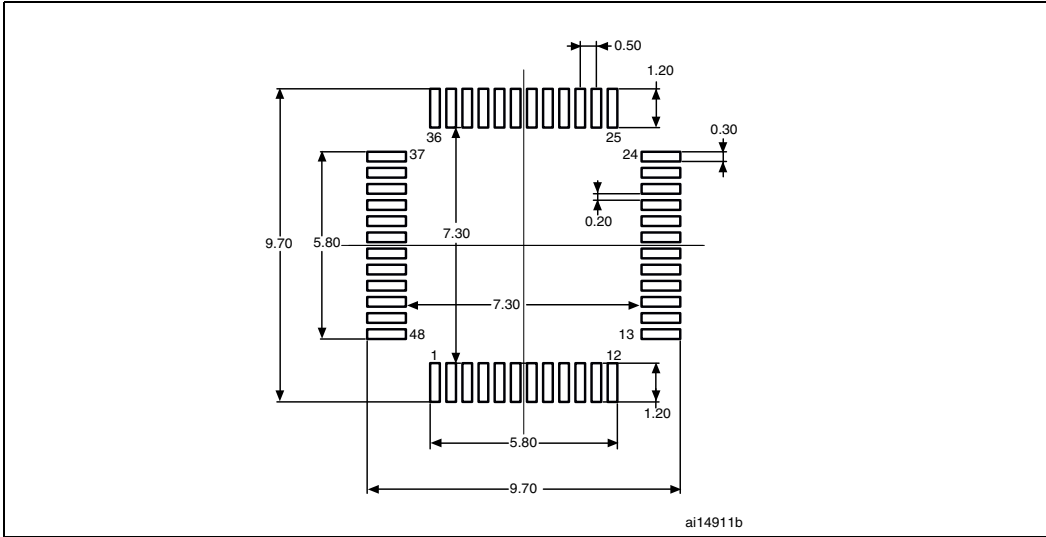
1. Drawing is not to scale.

Table 59. LQFP48 – 7 x 7 mm, 48-pin low-profile quad flat package mechanical data

Symbol	millimeters			inches <sup>(1)</sup>		
	Min	Typ	Max	Min	Typ	Max
A			1.600			0.0630
A1	0.050		0.150	0.0020		0.0059
A2	1.350	1.400	1.450	0.0531	0.0551	0.0571
b	0.170	0.220	0.270	0.0067	0.0087	0.0106
c	0.090		0.200	0.0035		0.0079
D	8.800	9.000	9.200	0.3465	0.3543	0.3622
D1	6.800	7.000	7.200	0.2677	0.2756	0.2835
D3		5.500			0.2165	
E	8.800	9.000	9.200	0.3465	0.3543	0.3622
E1	6.800	7.000	7.200	0.2677	0.2756	0.2835
E3		5.500			0.2165	
e		0.500			0.0197	
L	0.450	0.600	0.750	0.0177	0.0236	0.0295
L1		1.000			0.0394	
k	0°	3.5°	7°	0°	3.5°	7°
ccc		0.080			0.0031	

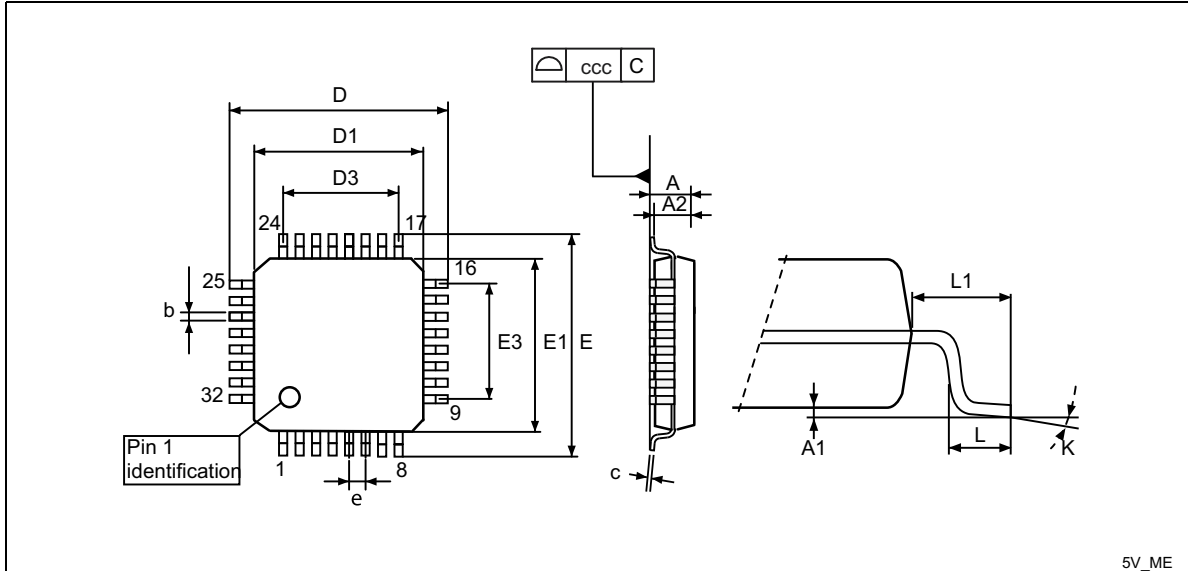
1. Values in inches are converted from mm and rounded to 4 decimal digits.

Figure 29. LQFP48 recommended footprint



- 1. Drawing is not to scale.
- 2. Dimensions are in millimeters.

Figure 30. LQFP32 – 7 x 7mm 32-pin low-profile quad flat package outline



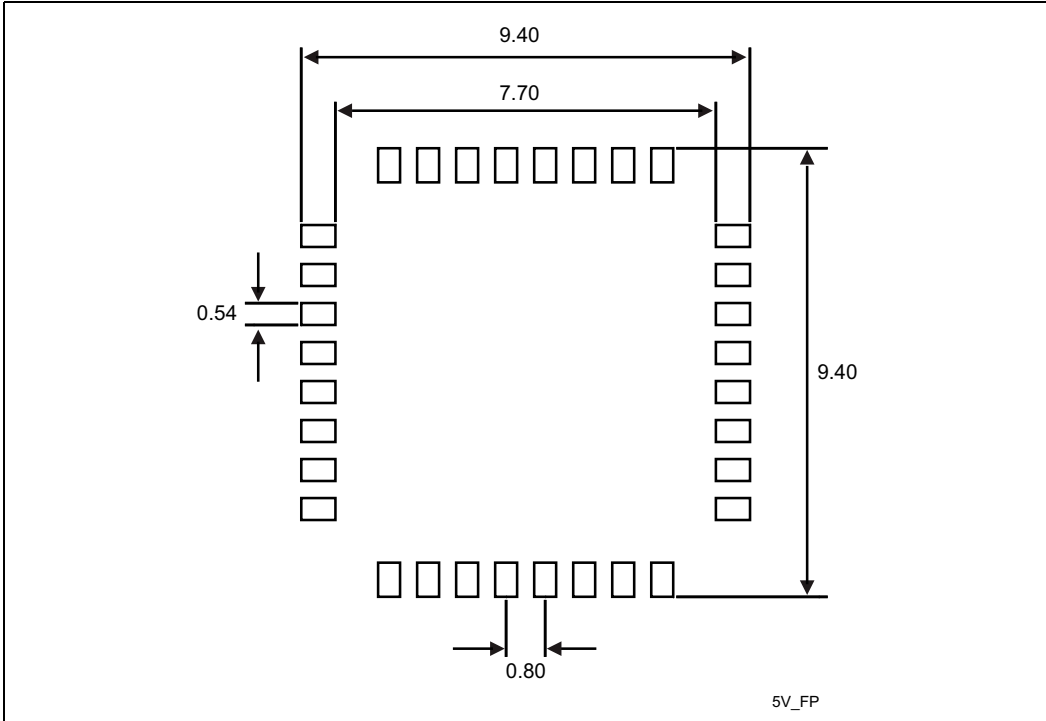
1. Drawing is not to scale.

Table 60. LQFP32 – 7 x 7mm 32-pin low-profile quad flat package mechanical data

Symbol	millimeters			inches <sup>(1)</sup>		
	Min	Typ	Max	Min	Typ	Max
A			1.600			0.0630
A1	0.050		0.150	0.0020		0.0059
A2	1.350	1.400	1.450	0.0531	0.0551	0.0571
b	0.300	0.370	0.450	0.0118	0.0146	0.0177
c	0.090		0.200	0.0035		0.0079
D	8.800	9.000	9.200	0.3465	0.3543	0.3622
D1	6.800	7.000	7.200	0.2677	0.2756	0.2835
D3		5.600			0.2205	
E	8.800	9.000	9.200	0.3465	0.3543	0.3622
E1	6.800	7.000	7.200	0.2677	0.2756	0.2835
E3		5.600			0.2205	
e		0.800			0.0315	
L	0.450	0.600	0.750	0.0177	0.0236	0.0295
L1		1.000			0.0394	
k	0°	3.5°	7.0°	0°	3.5°	7.0°
ccc			0.100			0.0039

1. Values in inches are converted from mm and rounded to 4 decimal digits.

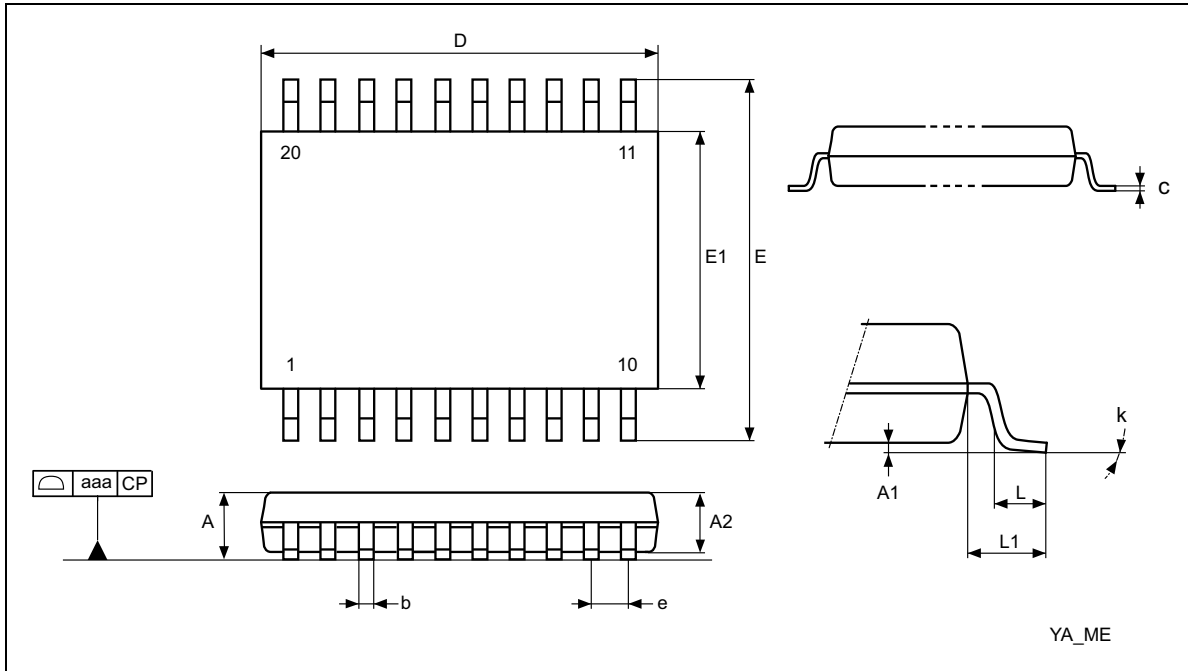
Figure 31. LQFP32 recommended footprint



- 1. Drawing is not to scale.
- 2. Dimensions are in millimeters.



Figure 32. TSSOP20 - 20-pin thin shrink small outline



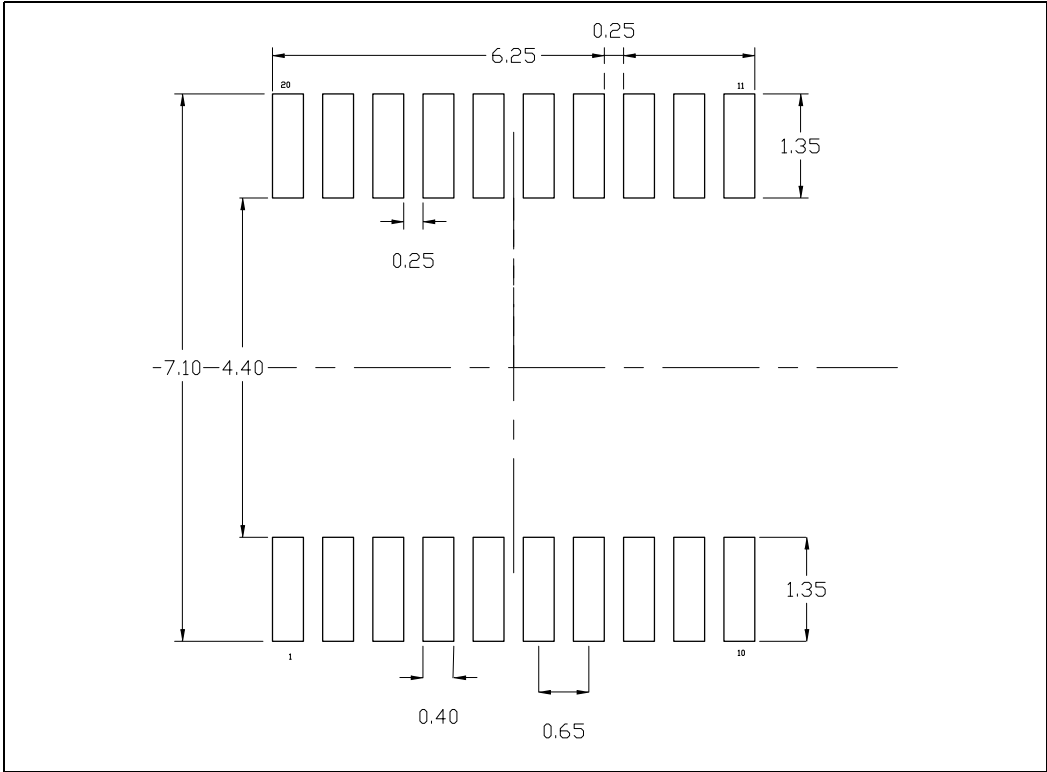
1. Drawing is not to scale.

Table 61. TSSOP20 – 20-pin thin shrink small outline package mechanical data

Symbol	millimeters			inches <sup>(1)</sup>		
	Min	Typ	Max	Min	Typ	
A			1.2			0.0472
A1	0.05		0.15	0.002		0.0059
A2	0.8	1	1.05	0.0315	0.0394	0.0413
b	0.19		0.3	0.0075		0.0118
c	0.09		0.2	0.0035		0.0079
D	6.4	6.5	6.6	0.252	0.2559	0.2598
E	6.2	6.4	6.6	0.2441	0.252	0.2598
E1	4.3	4.4	4.5	0.1693	0.1732	0.1772
e		0.65			0.0256	
L	0.45	0.6	0.75	0.0177	0.0236	0.0295
L1		1			0.0394	
k	0.0°		8.0°	0.0°		8.0°
aaa			0.1			0.0039

1. Values in inches are converted from mm and rounded to 4 decimal digits.

Figure 33. TSSOP20 recommended footprint



1. Dimensions are in millimeters



## 7.2 Thermal characteristics

The maximum chip junction temperature ( $T_J$  max) must never exceed the values given in [Table 18: General operating conditions](#).

The maximum chip-junction temperature,  $T_J$  max, in degrees Celsius, may be calculated using the following equation:

$$T_J \text{ max} = T_A \text{ max} + (P_D \text{ max} \times \Theta_{JA})$$

Where:

- $T_A$  max is the maximum ambient temperature in °C,
- $\Theta_{JA}$  is the package junction-to-ambient thermal resistance, in °C/W,
- $P_D$  max is the sum of  $P_{INT}$  max and  $P_{I/O}$  max ( $P_D$  max =  $P_{INT}$  max +  $P_{I/O}$  max),
- $P_{INT}$  max is the product of  $I_{DD}$  and  $V_{DD}$ , expressed in Watts. This is the maximum chip internal power.

$P_{I/O}$  max represents the maximum power dissipation on output pins where:

$$P_{I/O} \text{ max} = \Sigma (V_{OL} \times I_{OL}) + \Sigma ((V_{DD} - V_{OH}) \times I_{OH}),$$

taking into account the actual  $V_{OL} / I_{OL}$  and  $V_{OH} / I_{OH}$  of the I/Os at low and high level in the application.

**Table 62. Package thermal characteristics**

Symbol	Parameter	Value	Unit
$\Theta_{JA}$	Thermal resistance junction-ambient LQFP64 - 10 × 10 mm / 0.5 mm pitch	45	°CW
	Thermal resistance junction-ambient LQFP48 - 7 × 7 mm	55	
	Thermal resistance junction-ambient LQFP32 - 7 × 7 mm	56	
	Thermal resistance junction-ambient TSSOP20	110	

### 7.2.1 Reference document

JESD51-2 Integrated Circuits Thermal Test Method Environment Conditions - Natural Convection (Still Air). Available from [www.jedec.org](http://www.jedec.org)

### 7.2.2 Selecting the product temperature range

When ordering the microcontroller, the temperature range is specified in the ordering information scheme shown in [Section 8: Part numbering](#).

Each temperature range suffix corresponds to a specific guaranteed ambient temperature at maximum dissipation and, to a specific maximum junction temperature.

As applications do not commonly use the STM32F0xx at maximum dissipation, it is useful to calculate the exact power consumption and junction temperature to determine which temperature range will be best suited to the application.

The following examples show how to calculate the temperature range needed for a given application.

**Example 1: High-performance application**

Assuming the following application conditions:

Maximum ambient temperature  $T_{Amax} = 82\text{ }^{\circ}\text{C}$  (measured according to JESD51-2),  
 $I_{DDmax} = 50\text{ mA}$ ,  $V_{DD} = 3.5\text{ V}$ , maximum 20 I/Os used at the same time in output at low level with  $I_{OL} = 8\text{ mA}$ ,  $V_{OL} = 0.4\text{ V}$  and maximum 8 I/Os used at the same time in output at low level with  $I_{OL} = 20\text{ mA}$ ,  $V_{OL} = 1.3\text{ V}$

$$P_{INTmax} = 50\text{ mA} \times 3.5\text{ V} = 175\text{ mW}$$

$$P_{IOmax} = 20 \times 8\text{ mA} \times 0.4\text{ V} + 8 \times 20\text{ mA} \times 1.3\text{ V} = 272\text{ mW}$$

This gives:  $P_{INTmax} = 175\text{ mW}$  and  $P_{IOmax} = 272\text{ mW}$ :

$$P_{Dmax} = 175 + 272 = 447\text{ mW}$$

Using the values obtained in [Table 62](#)  $T_{Jmax}$  is calculated as follows:

– For LQFP64,  $45\text{ }^{\circ}\text{C/W}$

$$T_{Jmax} = 82\text{ }^{\circ}\text{C} + (45\text{ }^{\circ}\text{C/W} \times 447\text{ mW}) = 82\text{ }^{\circ}\text{C} + 20.115\text{ }^{\circ}\text{C} = 102.115\text{ }^{\circ}\text{C}$$

This is within the range of the suffix 6 version parts ( $-40 < T_J < 105\text{ }^{\circ}\text{C}$ ) see [Table 18: General operating conditions](#).

In this case, parts must be ordered at least with the temperature range suffix 6 (see [Section 8: Part numbering](#)).

*Note:* With this given  $P_{Dmax}$  we can find the  $T_{Amax}$  allowed for a given device temperature range (order code suffix 6 or 7).

$$\text{Suffix 6: } T_{Amax} = T_{Jmax} - (45\text{ }^{\circ}\text{C/W} \times 447\text{ mW}) = 102.115 - 20.115 = 82.000\text{ }^{\circ}\text{C}$$

$$\text{Suffix 7: } T_{Amax} = T_{Jmax} - (45\text{ }^{\circ}\text{C/W} \times 447\text{ mW}) = 125 - 20.115 = 104.885\text{ }^{\circ}\text{C}$$

**Example 2: High-temperature application**

Using the same rules, it is possible to address applications that run at high ambient temperatures with a low dissipation, as long as junction temperature  $T_J$  remains within the specified range.

Assuming the following application conditions:

Maximum ambient temperature  $T_{Amax} = 100\text{ }^{\circ}\text{C}$  (measured according to JESD51-2),  
 $I_{DDmax} = 20\text{ mA}$ ,  $V_{DD} = 3.5\text{ V}$ , maximum 20 I/Os used at the same time in output at low level with  $I_{OL} = 8\text{ mA}$ ,  $V_{OL} = 0.4\text{ V}$

$$P_{INTmax} = 20\text{ mA} \times 3.5\text{ V} = 70\text{ mW}$$

$$P_{IOmax} = 20 \times 8\text{ mA} \times 0.4\text{ V} = 64\text{ mW}$$

This gives:  $P_{INTmax} = 70\text{ mW}$  and  $P_{IOmax} = 64\text{ mW}$ :

$$P_{Dmax} = 70 + 64 = 134\text{ mW}$$

Thus:  $P_{Dmax} = 134\text{ mW}$

Using the values obtained in [Table 62](#)  $T_{Jmax}$  is calculated as follows:

– For LQFP64,  $45\text{ }^{\circ}\text{C/W}$

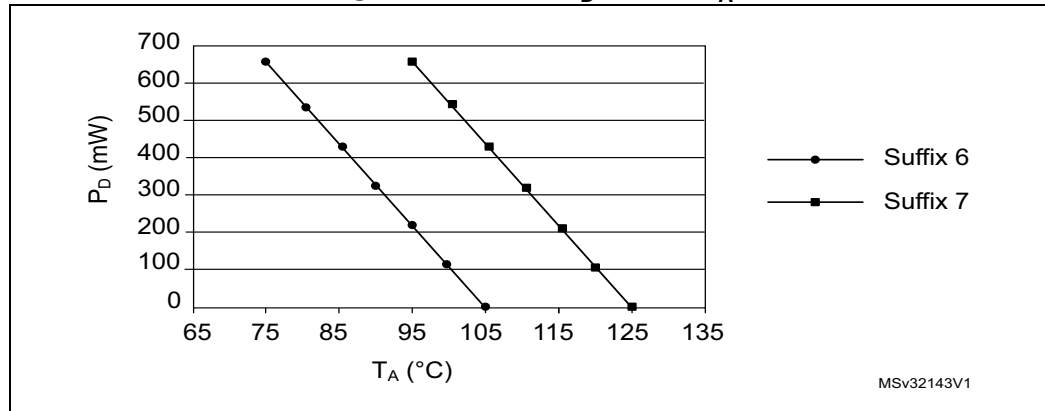
$$T_{Jmax} = 100\text{ }^{\circ}\text{C} + (45\text{ }^{\circ}\text{C/W} \times 134\text{ mW}) = 100\text{ }^{\circ}\text{C} + 6.03\text{ }^{\circ}\text{C} = 106.03\text{ }^{\circ}\text{C}$$

This is above the range of the suffix 6 version parts ( $-40 < T_J < 105\text{ }^{\circ}\text{C}$ ).

In this case, parts must be ordered at least with the temperature range suffix 7 (see [Section 8: Part numbering](#)) unless we reduce the power dissipation in order to be able to use suffix 6 parts.

Refer to [Figure 34](#) to select the required temperature range (suffix 6 or 7) according to your ambient temperature or power requirements. For suffix 7, refer to STM32F05x devices.

Figure 34. LQFP64  $P_D$  max vs.  $T_A$



## 8 Part numbering

For a list of available options (memory, package, and so on) or for further information on any aspect of this device, please contact your nearest ST sales office.

**Table 63. Ordering information scheme**

Example:	STM32	F	030	R	8	T	6	x
<b>Device family</b> STM32 = ARM-based 32-bit microcontroller								
<b>Product type</b> F = General-purpose								
<b>Sub-family</b> 030 = STM32F030xx								
<b>Pin count</b> F = 20 pins K = 32 pins C = 48 pins R = 64 pins								
<b>Code size</b> 4 = 16 Kbytes of Flash memory 6 = 32 Kbytes of Flash memory 8 = 64 Kbytes of Flash memory								
<b>Package</b> P = TSSOP T = LQFP								
<b>Temperature range</b> 6 = -40 °C to +85 °C								
<b>Options</b> TR = tape and reel								

## 9 Revision history

Table 64. Document revision history

Date	Revision	Changes
04-Jul-2013	1	Initial release

**Please Read Carefully:**

Information in this document is provided solely in connection with ST products. STMicroelectronics NV and its subsidiaries ("ST") reserve the right to make changes, corrections, modifications or improvements, to this document, and the products and services described herein at any time, without notice.

All ST products are sold pursuant to ST's terms and conditions of sale.

Purchasers are solely responsible for the choice, selection and use of the ST products and services described herein, and ST assumes no liability whatsoever relating to the choice, selection or use of the ST products and services described herein.

No license, express or implied, by estoppel or otherwise, to any intellectual property rights is granted under this document. If any part of this document refers to any third party products or services it shall not be deemed a license grant by ST for the use of such third party products or services, or any intellectual property contained therein or considered as a warranty covering the use in any manner whatsoever of such third party products or services or any intellectual property contained therein.

**UNLESS OTHERWISE SET FORTH IN ST'S TERMS AND CONDITIONS OF SALE ST DISCLAIMS ANY EXPRESS OR IMPLIED WARRANTY WITH RESPECT TO THE USE AND/OR SALE OF ST PRODUCTS INCLUDING WITHOUT LIMITATION IMPLIED WARRANTIES OF MERCHANTABILITY, FITNESS FOR A PARTICULAR PURPOSE (AND THEIR EQUIVALENTS UNDER THE LAWS OF ANY JURISDICTION), OR INFRINGEMENT OF ANY PATENT, COPYRIGHT OR OTHER INTELLECTUAL PROPERTY RIGHT.**

**ST PRODUCTS ARE NOT AUTHORIZED FOR USE IN WEAPONS. NOR ARE ST PRODUCTS DESIGNED OR AUTHORIZED FOR USE IN: (A) SAFETY CRITICAL APPLICATIONS SUCH AS LIFE SUPPORTING, ACTIVE IMPLANTED DEVICES OR SYSTEMS WITH PRODUCT FUNCTIONAL SAFETY REQUIREMENTS; (B) AERONAUTIC APPLICATIONS; (C) AUTOMOTIVE APPLICATIONS OR ENVIRONMENTS, AND/OR (D) AEROSPACE APPLICATIONS OR ENVIRONMENTS. WHERE ST PRODUCTS ARE NOT DESIGNED FOR SUCH USE, THE PURCHASER SHALL USE PRODUCTS AT PURCHASER'S SOLE RISK, EVEN IF ST HAS BEEN INFORMED IN WRITING OF SUCH USAGE, UNLESS A PRODUCT IS EXPRESSLY DESIGNATED BY ST AS BEING INTENDED FOR "AUTOMOTIVE, AUTOMOTIVE SAFETY OR MEDICAL" INDUSTRY DOMAINS ACCORDING TO ST PRODUCT DESIGN SPECIFICATIONS. PRODUCTS FORMALLY ESCC, QML OR JAN QUALIFIED ARE DEEMED SUITABLE FOR USE IN AEROSPACE BY THE CORRESPONDING GOVERNMENTAL AGENCY.**

Resale of ST products with provisions different from the statements and/or technical features set forth in this document shall immediately void any warranty granted by ST for the ST product or service described herein and shall not create or extend in any manner whatsoever, any liability of ST.

ST and the ST logo are trademarks or registered trademarks of ST in various countries.

Information in this document supersedes and replaces all information previously supplied.

The ST logo is a registered trademark of STMicroelectronics. All other names are the property of their respective owners.

© 2013 STMicroelectronics - All rights reserved

STMicroelectronics group of companies

Australia - Belgium - Brazil - Canada - China - Czech Republic - Finland - France - Germany - Hong Kong - India - Israel - Italy - Japan - Malaysia - Malta - Morocco - Philippines - Singapore - Spain - Sweden - Switzerland - United Kingdom - United States of America

[www.st.com](http://www.st.com)