



ON Semiconductor®

Ordering number : EN3949E

ON Semiconductor **DATA SHEET**

LB1838M

Monolithic Digital IC
**Low-Voltage, Low-Saturation
Bidirectional Motor Driver**

Overview

The LB1838M is a low-saturation two-channel bidirectional motor driver IC for use in low-voltage applications.

The LB1838M is a bipolar stepper-motor driver IC that is ideal for use in printers, cameras and other portable devices.

Functions

- Low voltage operation (2.5V min)
- Low saturation voltage (upper transistor + lower transistor residual voltage: 0.40V at 400mA)
- Built-in through-current prevention circuit
- Separate logic power supply and motor power supply
- Built-in spark killer diodes
- Built-in thermal shutdown circuit
- Compact package: MFP14S

Specifications

Absolute Maximum Ratings at $T_a = 25^\circ\text{C}$

Parameter	Symbol	Conditions	Ratings	Unit
Maximum supply voltage	$V_{CC\ max}$		-0.3 to +10.5	V
	$V_S\ max$		-0.3 to +10.5	V
Output applied voltage	V_{OUT}		$V_S + V_{SF}$	V
Input applied voltage	V_{IN}		-0.3 to +10	V
Ground pin flow-out current	I_{GND}	Per channel	1.0	A
Allowable power dissipation	$P_d\ max$	Independent IC	550	mW
		Mounted on a specified board *	800	mW
Operating temperature	T_{opr}		-20 to +75	°C
Storage temperature	T_{stg}		-40 to +125	°C

* Specified board: 20mm × 30mm × 1.6mm, glass epoxy board.

LB1838M

Allowable Operating Ranges at Ta = 25°C

Parameter	Symbol	Conditions	Ratings	Unit
Supply voltage	V _{CC}		2.5 to 9.0	V
	V _S		1.8 to 9.0	V
Input high-level voltage	V _{IH}		1.8 to 9.0	V
Input Low-level voltage	V _{IL}		-0.3 to +0.7	V

Electrical Characteristics at Ta = 25°C, V_{CC} = 3V

Parameter	Symbol	Conditions	Ratings			Unit
			min	typ	max	
Current drain	I _{CC0}	ENA1,2 = 0V, V _{IN1} = 3V or 0V		0.1	10	μA
	I _{CC1}	ENA1 = 3V, V _{IN1} = 3V or 0V		12	18	mA
Output saturation voltage	V _{OUT1}	ENA = 3V, V _{IN} = 3V or 0V, I _{OUT} = 200mA		0.2	0.28	V
	V _{OUT2}	ENA = 3V, V _{IN} = 3V or 0V, I _{OUT} = 400mA		0.4	0.6	V
Input current	I _{IN}	V _{CC} = 6V, V _{IN} = 6V			200	μA
	I _{ENA}	V _{CC} = 6V, ENA = 6V			200	μA
Output sustaining voltage	V _{O(SUS)}	I _{OUT} = 400mA	9			V
Spark killer diode						
Reverse current	I _{S(leak)}	V _{CC1} , V _S = 7V			30	μA
Forward voltage	V _{SF}	I _{OUT} = 400mA			1.7	V

Package Dimensions

unit : mm (typ)

3111A

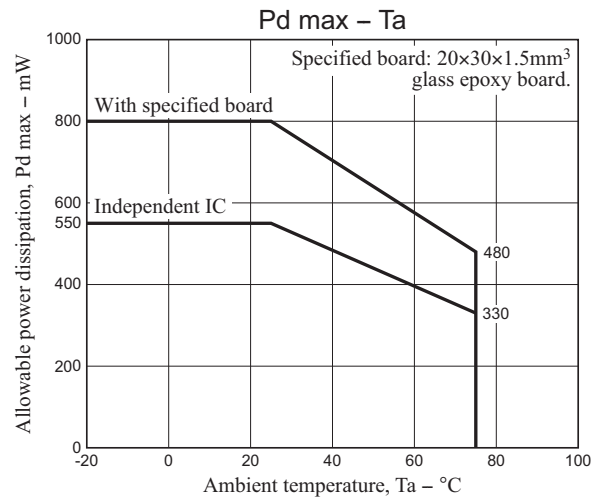
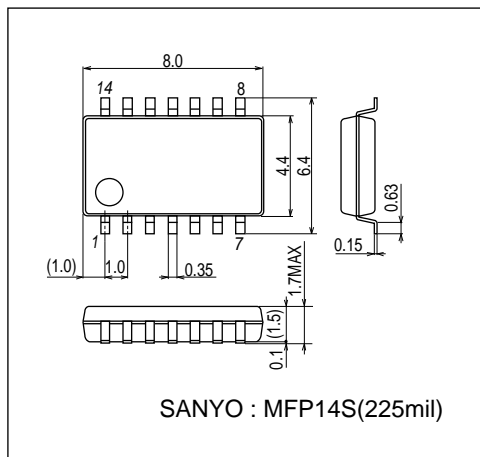

Pin Assignment

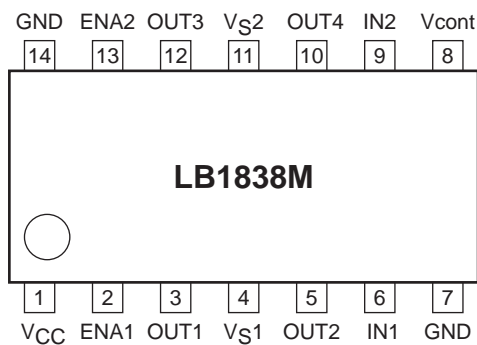

Note: Both GND pins should be connected to ground.

Block Diagram

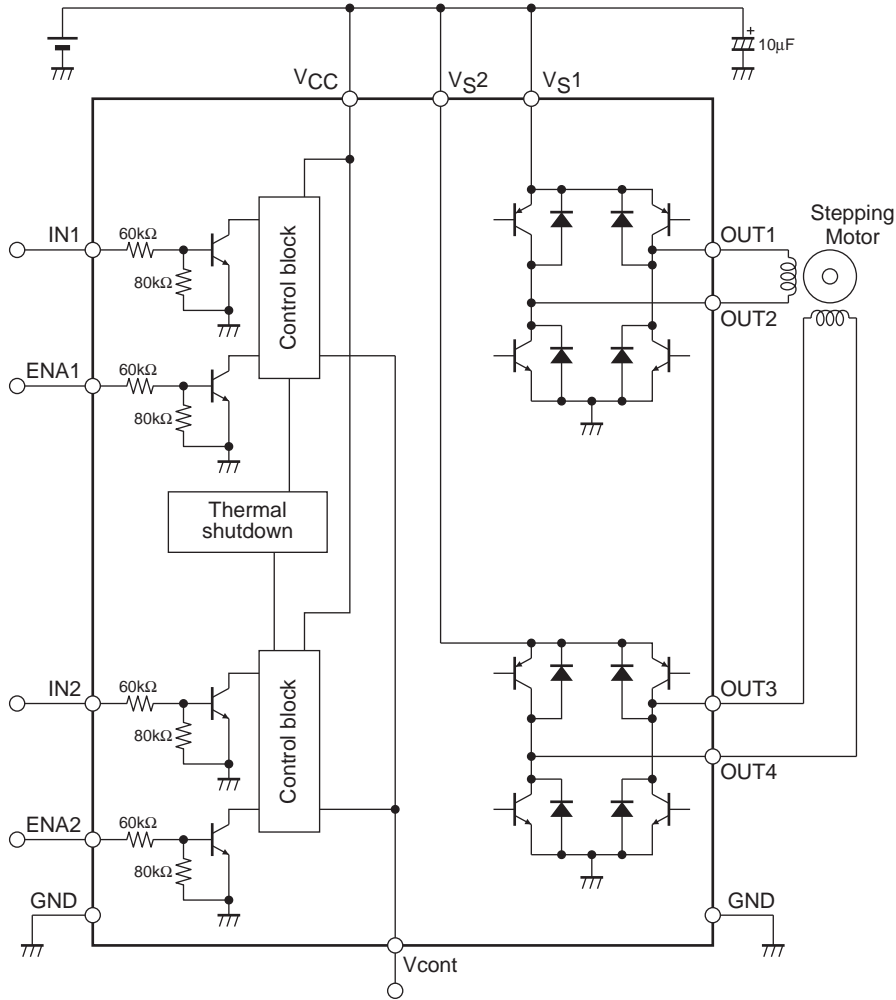

Note: As long as the voltages applied to VCC, VS1, VS2, ENA1, ENA2, IN1, and IN2 are within the limits set by the absolute maximum ratings, there are no restrictions on the relationship of each voltage level in comparison with the others (regarding which is higher or lower). (ex. VCC = 3V, VS1, 2 = 2V, ENA = IN = 5V)

Truth Table

IN1,2	ENA1,2	OUT1,3	OUT2,4	Mode
L	H	H	L	Forward
H	H	L	H	Reverse
L	L	OFF	OFF	Standby
H	L	OFF	OFF	Standby

Vcont pin

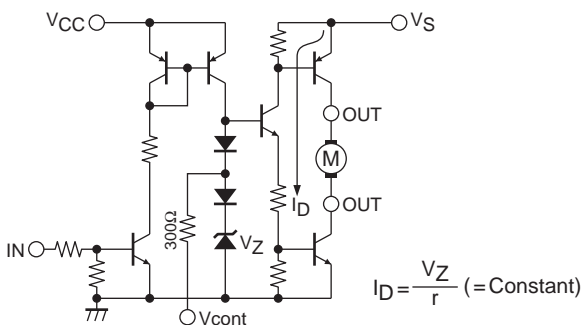

As shown in the left diagram, the Vcont pin outputs the voltage of the band gap Zener $V_Z + V_F (= 1.93V)$. In normal use, this pin is left open. The drive current I_D is varied by the Vcont voltage. However, because the band gap Zener is shared, it functions as a bridge.

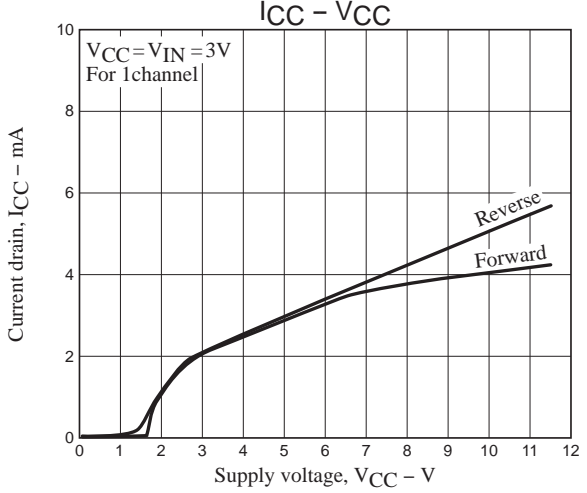
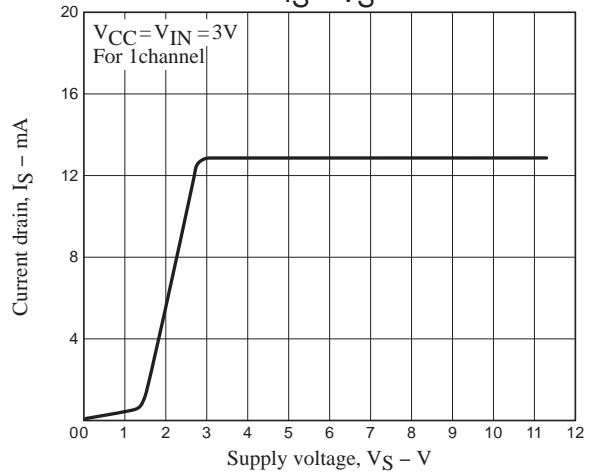
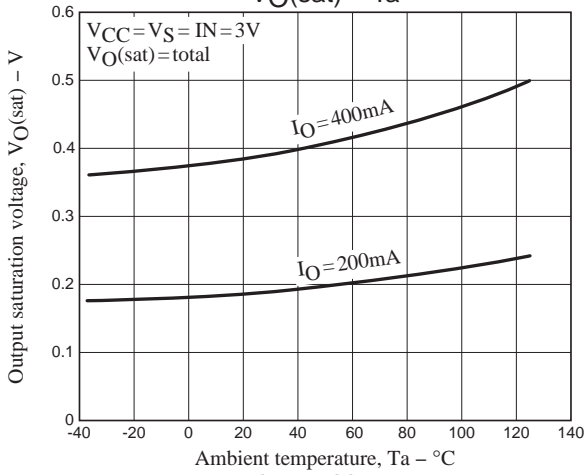
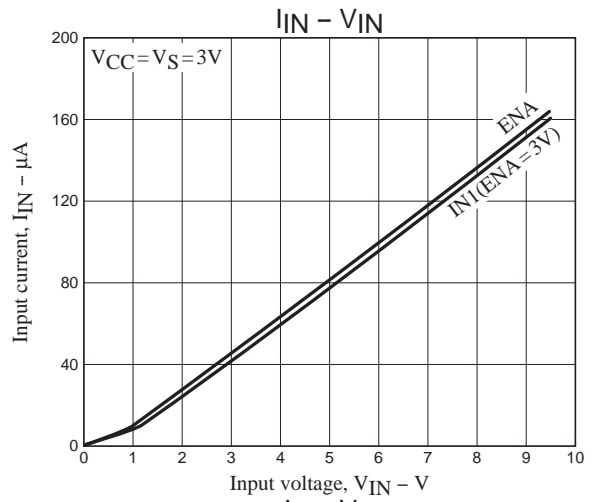
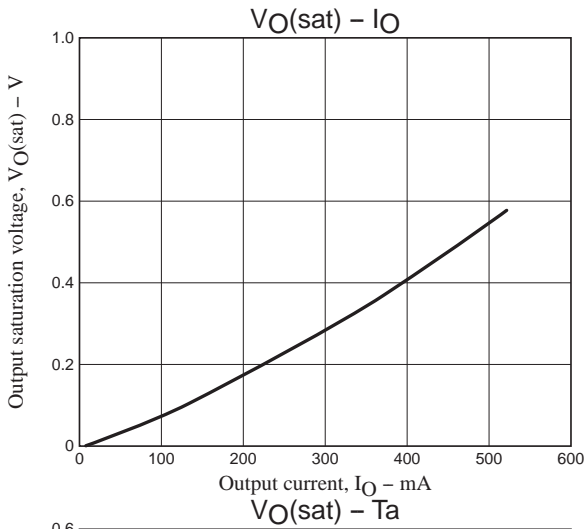

ON Semiconductor and the ON logo are registered trademarks of Semiconductor Components Industries, LLC (SCILLC). SCILLC reserves the right to make changes without further notice to any products herein. SCILLC makes no warranty, representation or guarantee regarding the suitability of its products for any particular purpose, nor does SCILLC assume any liability arising out of the application or use of any product or circuit, and specifically disclaims any and all liability, including without limitation special, consequential or incidental damages. SCILLC strives to supply high-quality high-reliability products and recommends adopting safety measures when designing equipment to avoid accidents or malfunctions. Such measures include but are not limited to protective circuits and error prevention circuits for safe design, redundant design, and structural design. "Typical" parameters which may be provided in SCILLC data sheets and/or specifications can and do vary in different applications and actual performance may vary over time. All operating parameters, including "Typicals," must be validated for each customer application by customer's technical experts. SCILLC shall not be held liable for any claim or suits with regard to a third party's intellectual property rights which has resulted from the use of the technical information and products mentioned above. SCILLC does not convey any license under its patent rights nor the rights of others. SCILLC products are not designed, intended, or authorized for use as components in systems intended for surgical implant into the body, or other applications intended to support or sustain life, or for any other application in which the failure of the SCILLC product could create a situation where personal injury or death may occur. Should Buyer purchase or use SCILLC products for any such unintended or unauthorized application, Buyer shall indemnify and hold SCILLC and its officers, employees, subsidiaries, affiliates, and distributors harmless against all claims, costs, damages, and expenses, and reasonable attorney fees arising out of, directly or indirectly, any claim of personal injury or death associated with such unintended or unauthorized use, even if such claim alleges that SCILLC was negligent regarding the design or manufacture of the part. SCILLC is an Equal Opportunity/Affirmative Action Employer. This literature is subject to all applicable copyright laws and is not for resale in any manner.

PUBLICATION ORDERING INFORMATION

LITERATURE FULFILLMENT:

Literature Distribution Center for ON Semiconductor
P.O. Box 5163, Denver, Colorado 80217 USA
Phone: 303-675-2175 or 800-344-3860 Toll Free USA/Canada
Fax: 303-675-2176 or 800-344-3867 Toll Free USA/Canada
Email: orderlit@onsemi.com

N. American Technical Support: 800-282-9855 Toll Free
USA/Canada
Europe, Middle East and Africa Technical Support:
Phone: 421 33 790 2910
Japan Customer Focus Center
Phone: 81-3-5773-3850

ON Semiconductor Website: www.onsemi.com

Order Literature: <http://www.onsemi.com/orderlit>

For additional information, please contact your local Sales Representative