

DATA SHEET

TDA1558Q

**2 x 22 W or 4 x 11 W single-ended
car radio power amplifier**

Product specification
File under Integrated Circuits, IC01

May 1992

2 x 22 W or 4 x 11 W single-ended car radio power amplifier

TDA1558Q

FEATURES

- Requires very few external components
- Flexibility in use Quad single-ended or stereo BTL
- High output power
- Low offset voltage at output (important for BTL)
- Fixed gain
- Good ripple rejection
- Mute/stand-by switch
- Load dump protection
- AC and DC short-circuit-safe to ground and V_P
- Thermally protected
- Reverse polarity safe
- Capability to handle high energy on outputs ($V_P = 0$)
- Protected against electrostatic discharge
- No switch-on/switch-off plop
- Flexible leads
- Low thermal resistance
- Identical inputs (inverting and non-inverting).

GENERAL DESCRIPTION

The TDA1558Q is a monolithic integrated class-B output amplifier in a 17-lead single-in-line (SIL) plastic power package. The device contains 4 x 11 W single-ended or 2 x 22 W BTL amplifiers and has been primarily developed for car radio applications.

QUICK REFERENCE DATA

SYMBOL	PARAMETER	CONDITIONS	MIN.	TYP.	MAX.	UNIT
V_P	positive supply voltage range	operating	6.0	14.4	18	V
I_{ORM}	repetitive peak output current		–	–	4	A
I_{tot}	total quiescent current		–	80	–	mA
I_{sb}	stand-by current		–	0.1	100	μ A
Stereo BTL application						
P_O	output power	THD = 10%; 4 Ω	–	22	–	W
SVRR	supply voltage ripple rejection		45	–	–	dB
V_{no}	noise output voltage	$R_S = 0$	–	200	–	μ V
$ Z_I $	input impedance		25	–	–	k Ω
$ \Delta V_{os} $	DC output offset voltage		–	–	250	mV
G_v	closed loop voltage gain		45	46	47	dB
Quad single-ended application						
P_O	output power	THD = 10%; 4 Ω	–	6	–	W
		THD = 10%; 2 Ω	–	11	–	W
SVRR	supply voltage ripple rejection		44	–	–	dB
V_{no}	noise output voltage	$R_S = 0$	–	150	–	μ V
$ Z_I $	input impedance		50	–	–	k Ω
G_v	closed loop voltage gain		39	40	41	dB

ORDERING INFORMATION

EXTENDED TYPE NUMBER	PACKAGE			
	PINS	PIN POSITION	MATERIAL	CODE
TDA1558Q	17	DIL	plastic	SOT243R ⁽¹⁾

Note

1. SOT243-1; 1996 August 21.

2 x 22 W or 4 x 11 W single-ended car
radio power amplifier

TDA1558Q

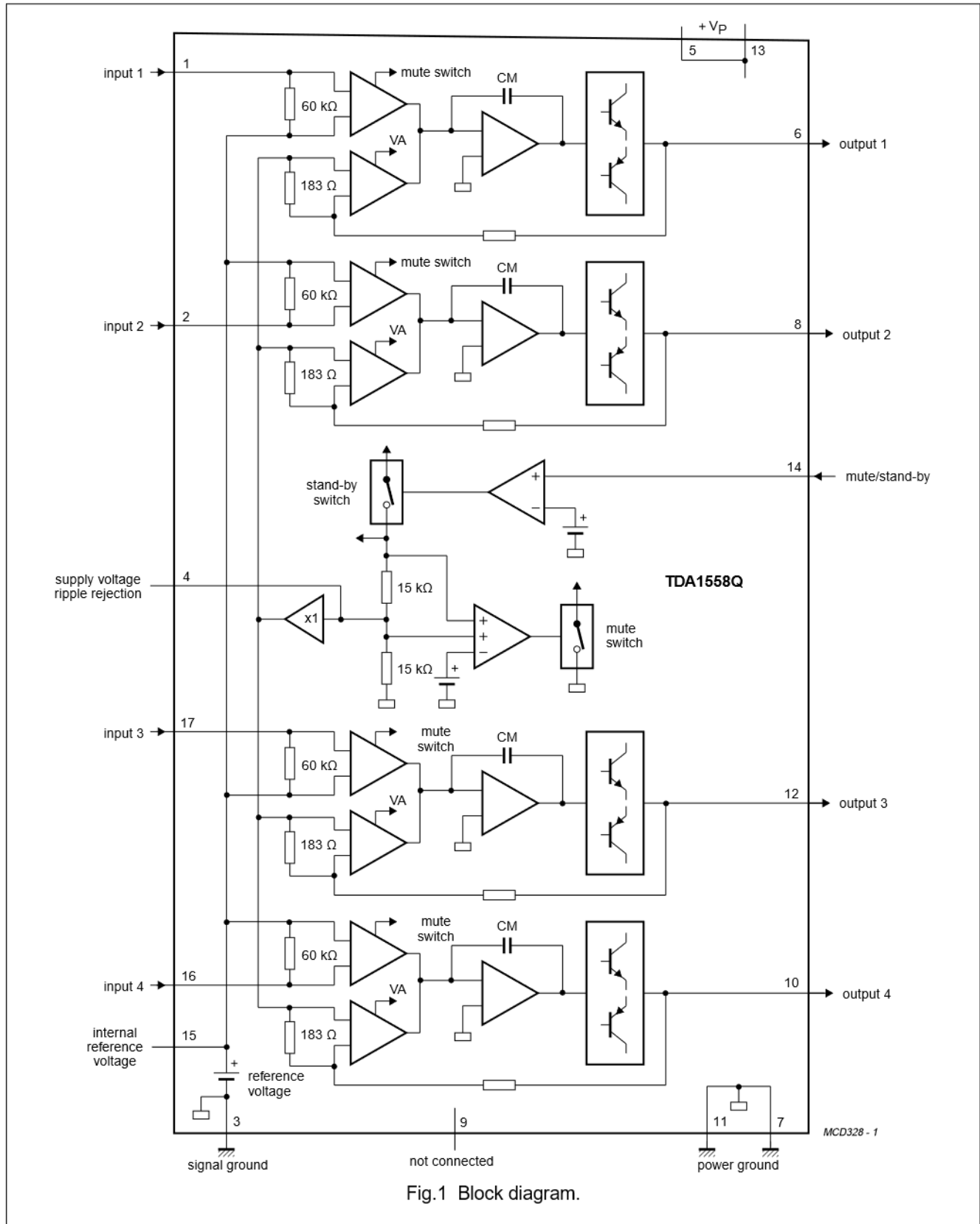

Fig.1 Block diagram.

2 x 22 W or 4 x 11 W single-ended car radio power amplifier

TDA1558Q

PINNING

SYMBOL	PIN	DESCRIPTION
-INV1	1	non-inverting input 1
INV2	2	inverting input 2
GND	3	ground (signal)
SVRR	4	supply voltage ripple rejection
V _{P1}	5	supply voltage
OUT1	6	output 1
GND1	7	power ground 1
OUT2	8	output 2
n.c.	9	not connected
OUT4	10	output 4
GND2	11	power ground 2
OUT3	12	output 3
V _{P2}	13	supply voltage
M/SS	14	mute/stand-by switch
V _{ref}	15	internal reference voltage
INV3	16	inverting input 3
-INV4	17	non-inverting input 4

FUNCTIONAL DESCRIPTION

The TDA1558Q contains four identical amplifiers with differential input stages (two inverting and two non-inverting), and can be used for single-ended or BTL applications. The gain of each amplifier is fixed at 40 dB (46 dB in BTL). Special features of this device are:

a. mute/stand-by switch

- low stand-by current (< 100 µA)
- low mute/stand-by switching current (low cost supply switch)
- mute facility.

b. the harmonic distortion at low frequencies can be decreased by connecting two diodes at pin 15 to ground or a zener diode of 1.5 V.

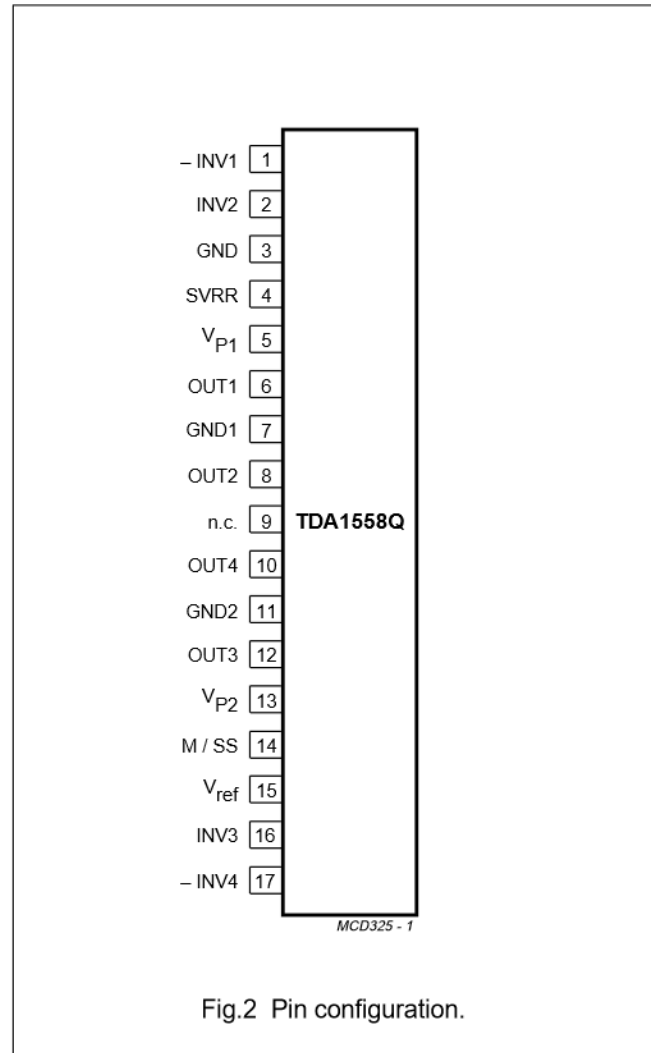

Fig.2 Pin configuration.

2 x 22 W or 4 x 11 W single-ended car radio power amplifier

TDA1558Q

LIMITING VALUES

In accordance with the Absolute maximum System (IEC 134).

SYMBOL	PARAMETER	CONDITIONS	MIN.	MAX.	UNIT
V_P	positive supply voltage	operating	-	18	V
		non-operating	-	30	V
		load dump protected; during 50 ms; rise time ≥ 2.5 ms	-	45	V
V_{PSC}	AC and DC short-circuit safe voltage		-	18	V
V_{PR}	reverse polarity		-	6	V
	energy handling capability at outputs	$V_P = 0$	-	200	mJ
I_{OSM}	non-repetitive peak output current		-	6	A
I_{ORM}	repetitive peak output current		-	4	A
P_{tot}	total power dissipation		-	60	W
T_{stg}	storage temperature range		-55	+150	$^{\circ}\text{C}$
T_j	junction temperature		-	+150	$^{\circ}\text{C}$

THERMAL RESISTANCE

SYMBOL	PARAMETER	THERMAL RESISTANCE
$R_{th\ vj-a}$	from virtual junction to ambient in free air	40 K/W
$R_{th\ vj-c}$	from virtual junction to case (see Fig.3)	1.5 K/W

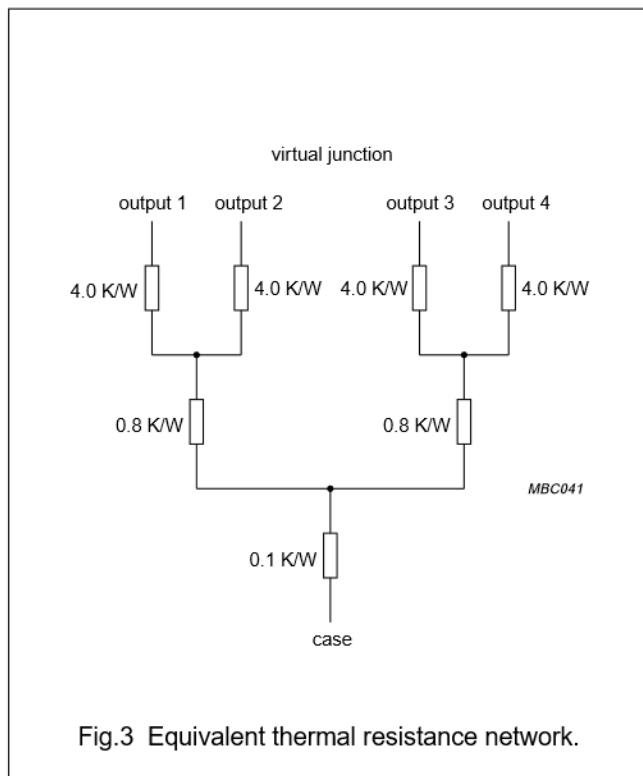

2 x 22 W or 4 x 11 W single-ended car radio power amplifier

TDA1558Q

DC CHARACTERISTICS

$V_P = 14.4$ V, $T_{amb} = 25$ °C, unless otherwise specified. See note 1.

SYMBOL	PARAMETER	CONDITIONS	MIN.	TYP.	MAX.	UNIT
Supply						
V_P	positive supply voltage range	note 2	6.0	14.4	18	V
I_P	quiescent current		-	80	160	mA
V_O	DC output voltage	note 3	-	6.9	-	V
$ \Delta V_{os} $	DC output offset voltage		-	-	250	mV
Mute/stand-by switch						
V_{ON}	switch-on voltage level		8.5	-	-	V
MUTE CONDITION						
V_{mute}	mute voltage		3.3	-	6.4	V
V_O	output signal in mute position	$V_1 = 1$ V (max); $f = 1$ kHz	-	-	20	mV
$ \Delta V_{os} $	DC output offset voltage	between pins 6-8 and pins 10-12	-	-	250	mV
STAND-BY CONDITION						
V_{sb}	stand-by voltage		0	-	2	V
I_{sb}	DC current in stand-by condition		-	-	100	μA
I_{sw}	switch-on current		-	12	40	μA

AC CHARACTERISTICS

$V_P = 14.4$ V, $R_L = 4$ Ω, $f = 1$ kHz, $T_{amb} = 25$ °C, unless otherwise specified. See note 1.

SYMBOL	PARAMETER	CONDITIONS	MIN.	TYP.	MAX.	UNIT
P_O	output power	THD = 0.5%	15	17	-	W
		THD = 10%	20	22	-	W
		$V_P = 13.2$ V; THD = 0.5%	-	12	-	W
		$V_P = 13.2$ V; THD = 10%	-	17	-	W
THD	total harmonic distortion	$P_O = 1$ W	-	0.1	-	%
B	power bandwidth	THD = 0.5%; $P_O = -1$ dB with respect to 15 W	-	20 to 15 000	-	Hz
f_{low}	low frequency roll-off	-1 dB; note 4	-	45	-	Hz
f_{high}	high frequency roll-off	-1 dB	20	-	-	kHz
G_V	closed loop voltage gain		45	46	47	dB
SVRR	supply voltage ripple rejection	ON; note 5	45	-	-	dB
		MUTE; note 5	45	-	-	dB
		stand-by; note 5	80	-	-	dB

2 x 22 W or 4 x 11 W single-ended car radio power amplifier

TDA1558Q

SYMBOL	PARAMETER	CONDITIONS	MIN.	TYP.	MAX.	UNIT
Z _i	input impedance		25	30	38	kΩ
V _{no}	noise output voltage	ON; R _S = 0; note 6	-	200	300	μV
		R _S = 10 kΩ; note 6	-	350	-	μV
		MUTE; notes 6 and 7	-	180	-	μV
α	channel separation	R _S = 10 kΩ	40	-	-	dB
ΔG _v	channel unbalance		-	-	1	dB
Quad single-ended application (see Fig.5)						
P _O	output power	note 8				
		THD = 0.5%	4	5	-	W
		THD = 10%	5.5	6	-	W
		R _L = 2 Ω; THD = 0.5%	7.5	8.5	-	W
		R _L = 2 Ω; THD = 10%	10	11	-	W
THD	total harmonic distortion	P _O = 1 W	-	0.1	-	%
f _{low}	low frequency roll-off	-3 dB; note 4	-	45	-	Hz
f _{high}	high frequency roll-off	-1 dB	20	-	-	kHz
G _v	closed loop voltage gain		39	40	41	dB
SVRR	supply voltage ripple rejection	note 5				
		ON	44	-	-	dB
		MUTE	44	-	-	dB
		stand-by	80	-	-	dB
Z _i	input impedance		50	60	75	kΩ
V _{no}	noise output voltage	ON; R _S = 0; note 6	-	150	230	μV
		R _S = 10 kΩ; note 6	-	250	-	μV
		MUTE; notes 6 and 7	-	120	-	μV
α	channel separation	R _S = 10 kΩ	40	-	-	dB
ΔG _v	channel unbalance		-	-	1	dB

Notes to the characteristics

- All characteristics are measured using the circuit shown in Fig.4
- The circuit is DC adjusted at V_P = 6 to 18 V and AC operating at V_P = 8.5 to 18 V.
- At 18 V < V_P < 30 V, the DC output voltage ≤ V_P/2.
- Frequency response externally fixed.
- Ripple rejection measured at the output with a source-impedance of 0 Ω (max. ripple amplitude of 2 V) and a frequency between 100 Hz and 10 kHz.
- Noise voltage measured in a bandwidth of 20 Hz to 20 kHz.
- Noise output voltage independent of R_S (V_{in} = 0).
- Output power is measured directly at the output pins of the IC.

2 x 22 W or 4 x 11 W single-ended car
radio power amplifier

TDA1558Q

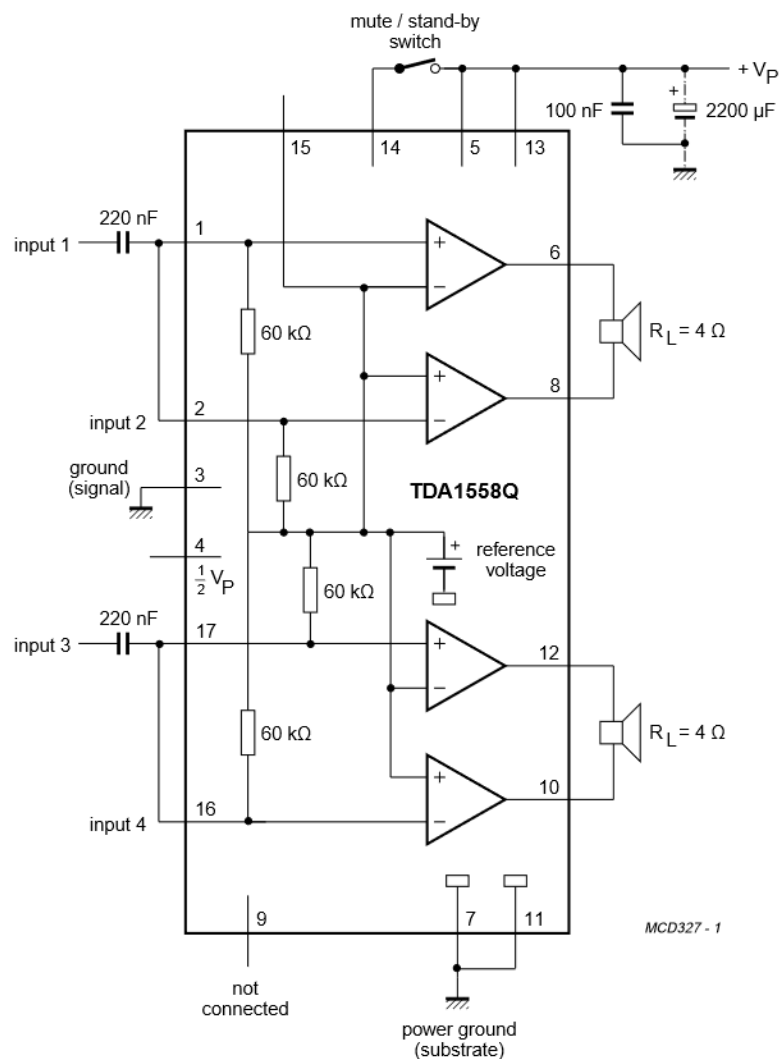

Fig.4 Stereo BTL application.

2 x 22 W or 4 x 11 W single-ended car
radio power amplifier

TDA1558Q

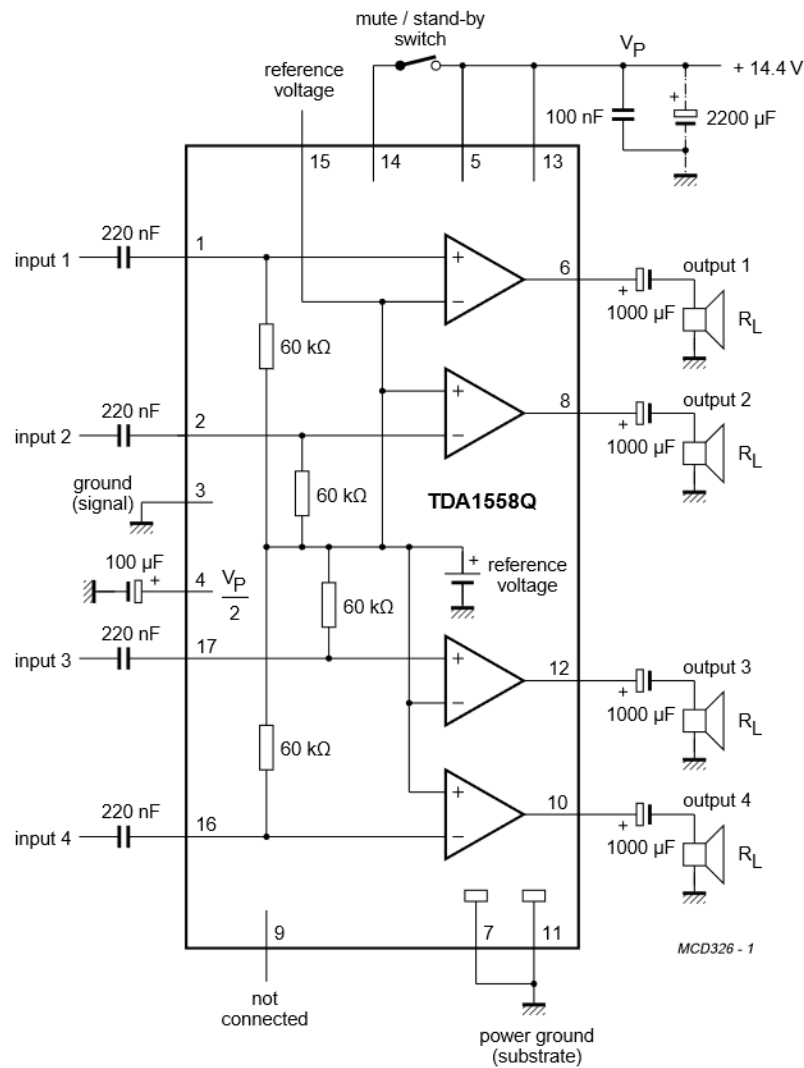

Fig.5 Quad single-ended application.

2 x 22 W or 4 x 11 W single-ended car
radio power amplifier

TDA1558Q

PACKAGE OUTLINE

DBS17P: plastic DIL-bent-SIL power package; 17 leads (lead length 12 mm)

SOT243-1

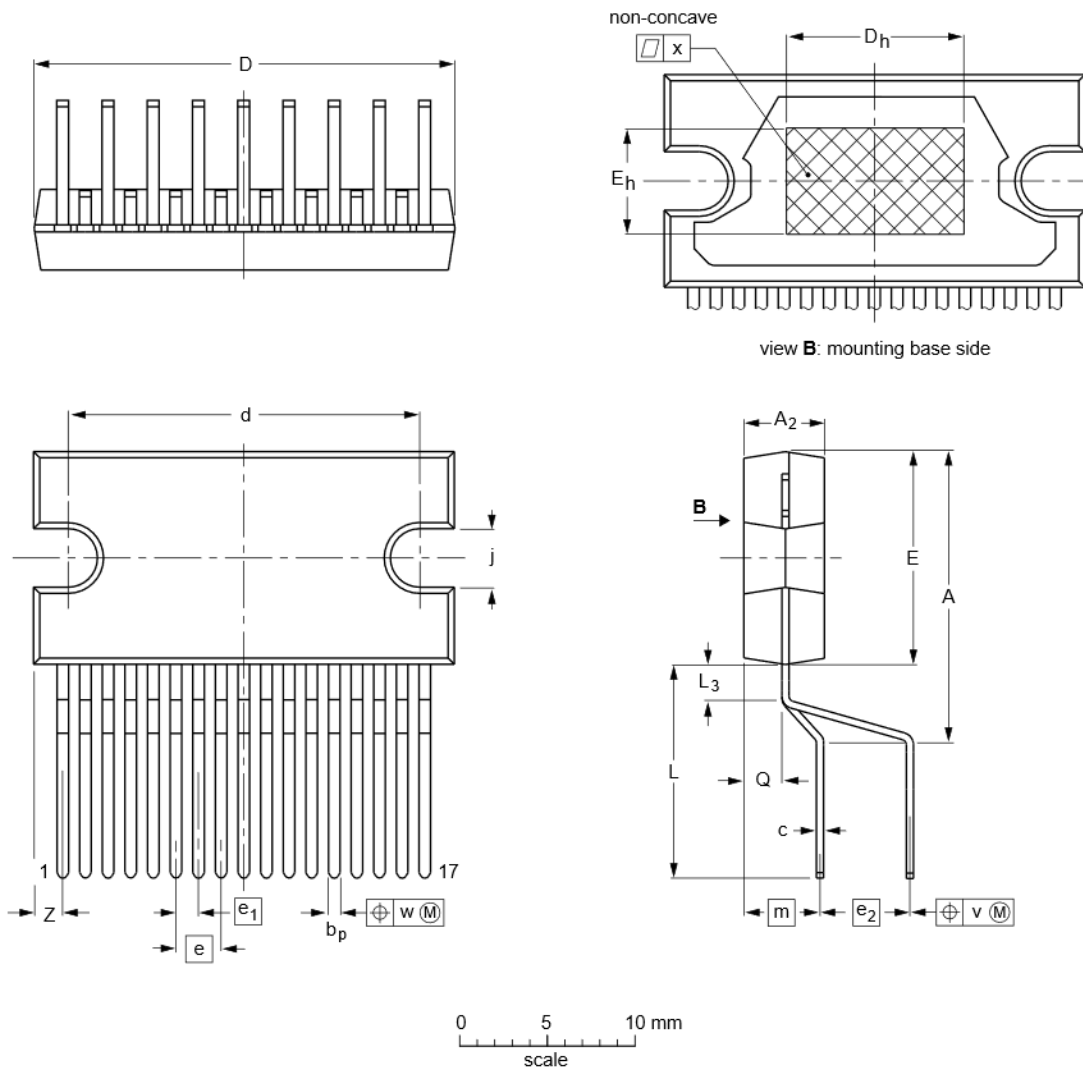

DIMENSIONS (mm are the original dimensions)

UNIT	A	A ₂	b _p	c	D ⁽¹⁾	d	D _h	E ⁽¹⁾	e	e ₁	e ₂	E _h	j	L	L ₃	m	Q	v	w	x	Z ⁽¹⁾
mm	17.0 15.5	4.6 4.2	0.75 0.60	0.48 0.38	24.0 23.6	20.0 19.6	10	12.2 11.8	2.54	1.27	5.08	6	3.4 3.1	12.4 11.0	2.4 1.6	4.3	2.1 1.8	0.8	0.4	0.03	2.00 1.45

Note

1. Plastic or metal protrusions of 0.25 mm maximum per side are not included.

OUTLINE VERSION	REFERENCES			EUROPEAN PROJECTION	ISSUE DATE
	IEC	JEDEC	EIAJ		
SOT243-1					92-11-17 95-03-11

2 x 22 W or 4 x 11 W single-ended car radio power amplifier

TDA1558Q

SOLDERING

Introduction

There is no soldering method that is ideal for all IC packages. Wave soldering is often preferred when through-hole and surface mounted components are mixed on one printed-circuit board. However, wave soldering is not always suitable for surface mounted ICs, or for printed-circuits with high population densities. In these situations reflow soldering is often used.

This text gives a very brief insight to a complex technology. A more in-depth account of soldering ICs can be found in our "IC Package Databook" (order code 9398 652 90011).

Soldering by dipping or by wave

The maximum permissible temperature of the solder is 260 °C; solder at this temperature must not be in contact with the joint for more than 5 seconds. The total contact time of successive solder waves must not exceed 5 seconds.

The device may be mounted up to the seating plane, but the temperature of the plastic body must not exceed the specified maximum storage temperature ($T_{stg\ max}$). If the printed-circuit board has been pre-heated, forced cooling may be necessary immediately after soldering to keep the temperature within the permissible limit.

Repairing soldered joints

Apply a low voltage soldering iron (less than 24 V) to the lead(s) of the package, below the seating plane or not more than 2 mm above it. If the temperature of the soldering iron bit is less than 300 °C it may remain in contact for up to 10 seconds. If the bit temperature is between 300 and 400 °C, contact may be up to 5 seconds.

DEFINITIONS

Data sheet status	
Objective specification	This data sheet contains target or goal specifications for product development.
Preliminary specification	This data sheet contains preliminary data; supplementary data may be published later.
Product specification	This data sheet contains final product specifications.
Limiting values	
Limiting values given are in accordance with the Absolute Maximum Rating System (IEC 134). Stress above one or more of the limiting values may cause permanent damage to the device. These are stress ratings only and operation of the device at these or at any other conditions above those given in the Characteristics sections of the specification is not implied. Exposure to limiting values for extended periods may affect device reliability.	
Application information	
Where application information is given, it is advisory and does not form part of the specification.	

LIFE SUPPORT APPLICATIONS

These products are not designed for use in life support appliances, devices, or systems where malfunction of these products can reasonably be expected to result in personal injury. Philips customers using or selling these products for use in such applications do so at their own risk and agree to fully indemnify Philips for any damages resulting from such improper use or sale.

