

REV.	DESCRIPTION	DATE	DRAWN	APPROVED
A1	DWG.REL	2016/10/7	FANG	YANG

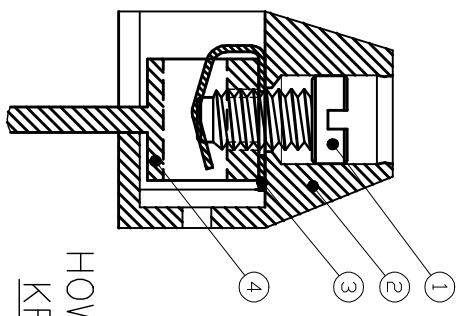

N=Number of Poles
 Dim P=(N-1)x3.50
 Dim L=Nx3.50

Poles	Dim P	Dim L
2-6P	±0.10	±0.15
7-12P	±0.20	±0.20
13-18P	±0.25	±0.30
19-24P	±0.30	±0.40

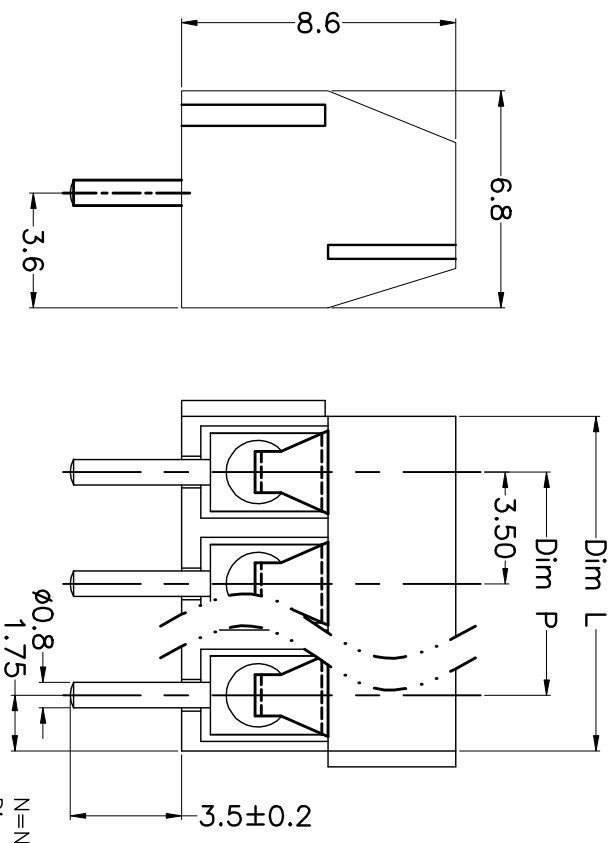
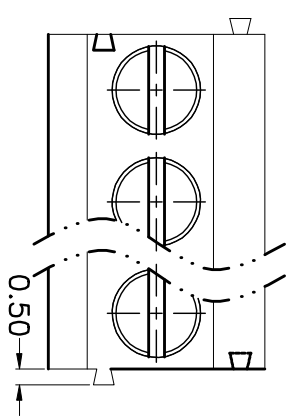
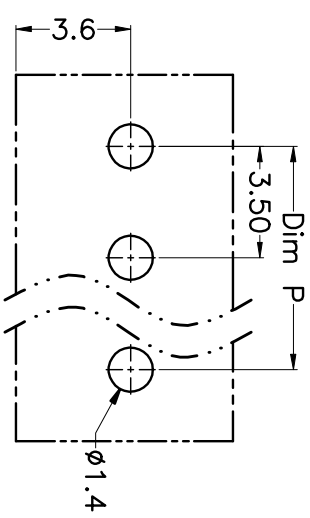

- Material
 - ①Screws : M2.0 steel, Zinc plated,
 - “-” slot type
 - ②Housing : PA66, UL94V-0
 - ③Reed : Phosphor bronze, Ni plated or stainless steel
 - ④Pin header : Brass, Tin plated

- Electrical

UL	IEC
Rated voltage : 300V	130V
Rated current : 16A	10A
Insulation resistance: 500MΩ/DC500V	
Withstanding Voltage : AC1250V/1min	
Wire range: 24-18AWG	1.0mm ²

- Mechanical
 - Operating temperature: -40°C~+105°C
 - Soldering temperature: 250°C±5/5sec
 - Torque: 0.2N.m (1.77Lb.in)
 - Strip length: 5-6mm

HOW TO ORDER
 KF350 V - 3.5 - XXP - 1 X - XXXXX

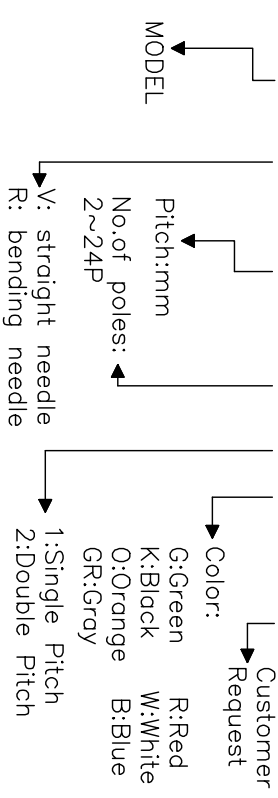

GENERAL TOLERANCE

X.	±0.5	X.	±5'
.X	±0.3	.X.	±3'
.XX	±0.1	.XX.	±1'

ANGLE TOLERANCE

DRAWING TYPE	CUSTOMER	SHEET	1 OF 1
SCALE	1:1	SHEET	1 OF 1

PROJECTION

UNITS	mm	TITLE	KF350V-3.5-XXP
SHEET SIZE	A4	SERIES	KF350V

KF 慈溪市凯峰电子有限公司
 KAIFENG ELECTRONIC CIXI KAIFENG ELECTRONIC CO.,LTD

