

REV.	DESCRIPTION	DATE	DRAWN	APPROVED
A1	DWG.REL	2016/10/7	FANG	YANG

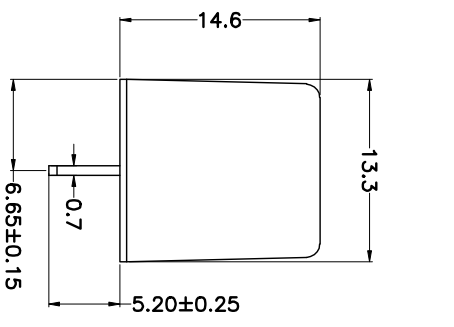

N=Number of Poles
 Dim P=(N-1)x7.62
 Dim L=Nx7.62+1.5

Poles	Dim P	Dim L
2-6P	±0.10	±0.15
7-12P	±0.20	±0.20
13-18P	±0.25	±0.30
19-24P	±0.30	±0.40

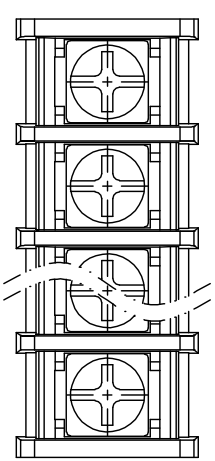
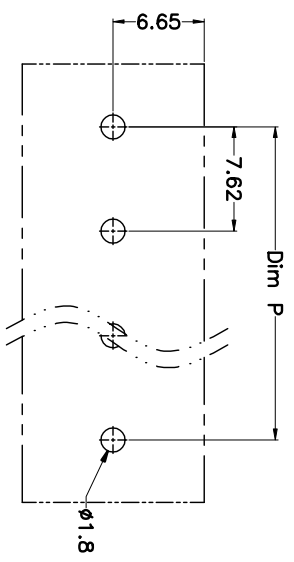
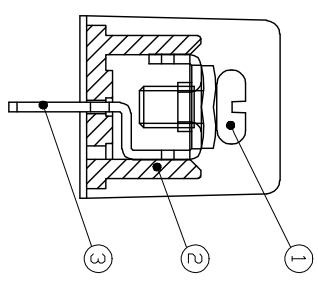
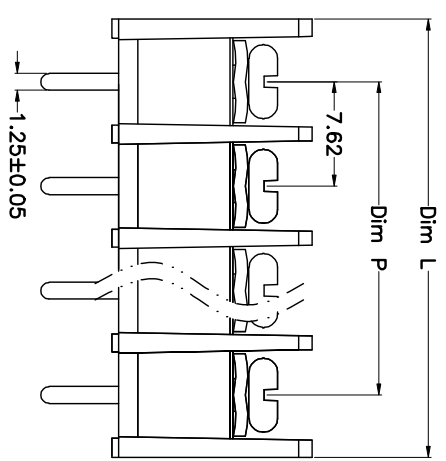

P.C.B.LAYOUT

- Material
 - ①Screws : M3.0 steel, Ni plated
 - ②Housing : PA66,UL94V-0
 - ③Terminal : Brass, Tin plated
- Electrical

UL	IEC
Rated voltage : 300V	250V
Rated current : 15A	24A
Insulation resistance: 500MΩ/DC500V	
Withstanding Voltage : AC2000V/1min	
Wire range: 22-14AWG	2.5mm ²
- Mechanical
 - Operating temperature: -40°C to +105°C
 - Soldering temperature: 250°C±5/5sec
 - Torque: 0.5N.m (4.43Lb.in)

HOW TO ORDER

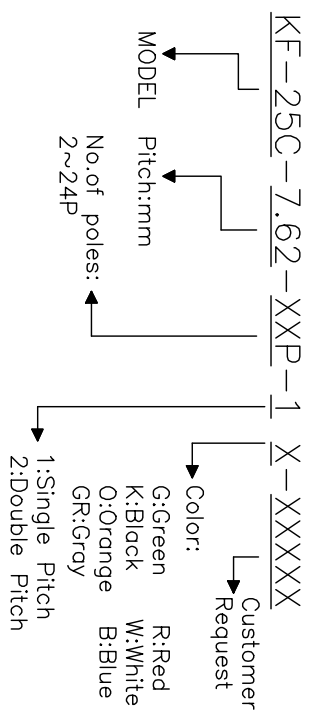

GENERAL TOLERANCE	ANGLE TOLERANCE
X: ±0.5	X: ±5'
.X: ±0.3	.X: ±3'
.XX: ±0.1	.XX: ±1'

DRAWING TYPE	CUSTOMER	SHEET	1 OF 1
SCALE	1:1		

DRAWING NO.	XP0012016-xxxx
-------------	----------------

PROJECTION	TITLE
mm	KF-25C-7.62-XXP

UNITS	SHEET SIZE	SERIES
mm	A4	KF-25C

KF 慈溪市凯峰电子有限公司
 KAIFENG ELECTRONIC CIXI KAIFENG ELECTRONIC CO.,LTD