

M11-F220

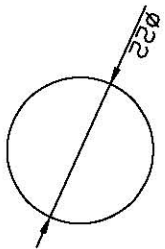

安装面板
PANEL CUT-OUT

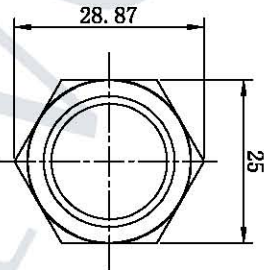
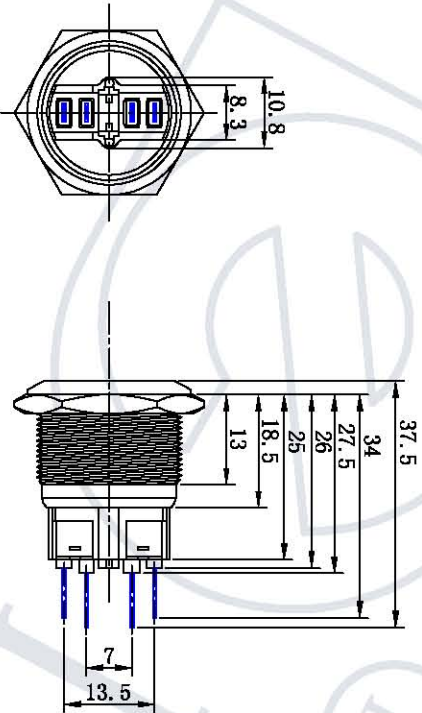
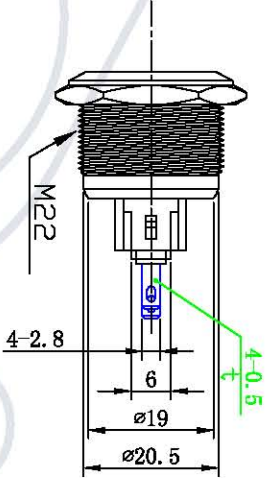
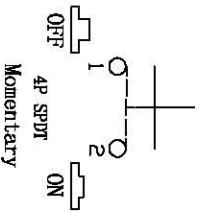

MATERIALS

- 1. Button: Stainless Steel
- 2. Bushing & Bezel: Stainless Steel
- 3. Base: PC
- 4. Contact : Silver, Gold Plated
- 5. Nut : Nickel plated brass

SPECIFICATIONS

1	Contact Rating:5A @ 250V
2	Electrical Life:50,000cycles
3	Contact Resistance:50m-ohms max(initial)
4	Insulation Resistance:1,000M-ohms min @ 500VDC
5	Dielectric Strength:2,000V RMS 50 ~ 60Hz
6	Operating Temperature:-20° C ~ +55° C
7	Switch function : INO INC
8	IP Class:IP65 Protection
9	Torque:5~14Nm max.applied to nut
10	Operating Force:5N max

标记	处数	分区	更改文件号	签字	日期
设计			标准化		
校对					
审核			批准		
工艺					

按钮开关

Yaoqing Dalar Electron co., Ltd	阶段标记	数量	重量	比例
Push Button Switch		1		1:1
GQ22F-11M	第一	页	第一	张

